



# NOVELTEK

MATERIAL HANDLING EQUIPMENT

*Made In Taiwan*

CE BY SGS (UK)  
ISO9001



FM96023



TAIWAN  
EXCELLENCE  
2016

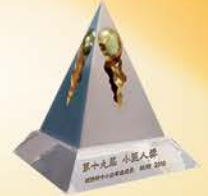

RISING STAR  
AWARD  
2016



IF YOU NEED THE MOVIE  
OF OUR PRODUCTS,  
WOULD YOU PLEASE  
CONTACT WITH US.

# NOVELTEK

# NOVELTEK

**NOVELTEK** is a leading Taiwanese manufacturer of powered and manual material handling equipment since 1990. We supply a full spectrum of models to provide you with a complete range of material handling equipment, and can manufacture equipment to comply with your special or unique requirement/ specifications. All our products are **Made In Taiwan (M.I.T.)**.

Our reputation for blending steadfast reliability and environmentalism has made **NOVELTEK** a well known and proven name in the industry. Our equipment is exported to 38 countries across the globe. Among these are Japan, Germany, the UK, Australia, the US, Canada, Sweden, Denmark, Norway, Belgium, Holland, Austria, Greece, Brazil, Mexico, India, Egypt, Tunisia, Jordan, Korea, Hong Kong and most Asian countries. We insist on delivering reliable, low maintenance equipment and we implement a strict quality control policy. **NOVELTEK** occupies a solid market share which continues to grow due to our endeavors in R&D as well as our comprehensive customer service. All of our products are CE and ISO 9001 certified and surpass 2006/42/EC and 2006/95/EC quality regulations. Clients count on **NOVELTEK** to raise productivity, shorten man hours and reduce cost in a variety of ways. With **NOVELTEK** material handling equipment, you can better manage your time before time gets the better of you.

We offer a wide variety of excellent machinery at very reasonable prices and guarantee the shortest delivery time.

We can provide feasible solution to your unique or special material handling situation. Please do not hesitate to contact us if you have any special requirements or inquiries.

We appreciate all of your support and look forward to developing a mutually beneficial relationship with you soon.

Regarding our shipping space, one 20 feet container can carry 5 units of ABF/ABT models; or 7 units of ART/CRT/ACS/CWS/CWR/POPS models; or 10 units of APS/PPS/POTR models; or 12 units of APT/PPT/SPOP/TT/ATT/MOTR models; or 18 units of MOTL models; or 21 units of SPS models; or 24 units of MPS-10 models; or 32 units of MPS-04 models, or 52 units of LT models; or 80 units of OT models; or 144 units of HPT models; or mix all models by percentage.



## ABF-15/20/25

### ADVANCED ELECTRIC FORKLIFT TRUCK (AC SYSTEM) (1.5 TONS / 2 TONS / 2.5 TONS)

- AC stepless inverter
- Save electricity efficiently by 30%
- Without carbon brush, easy maintenance
- No noise
- No pollution
- Can be turned in a 3.3 meter wide aisle for model ABF-15/20
- Soft solid tyres on 4 wheels
- Full hydraulic power steering
- Max fork lifting height between 2 meters and 6.35 meters
- Hydraulic power brake
- Mechanical hand parking brake
- Lead-free PU baked enamel painting
- Triple stage, full free lift mast, -35°C cold storage version, side shift, special attachment clamps, and explosion protection and shaft type forged forks are available as options.



Option: Digital weight scale



Microprocessor charger  
with equalizing function



## ★ ABF-15/20/25 Specification ★

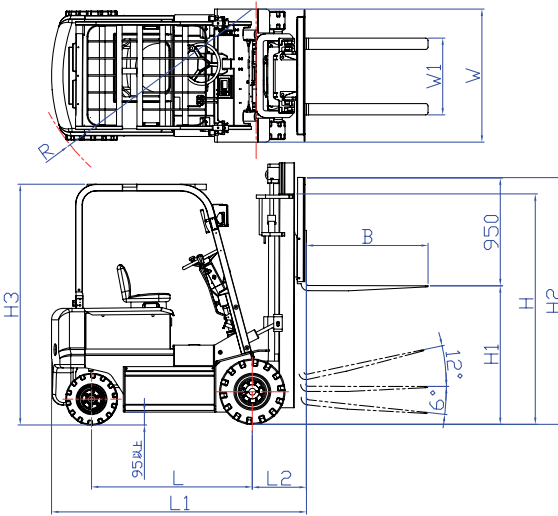

An easily read instrument panel makes it easy to control.



The tubular powerful Traction Battery with high capacity can handle a full work shift after 8 hours charge and has a 5 years life time when normally operated and maintained.

MODEL		ABF-15	ABF-20	ABF-25
Rated Capacity		1500 kg	2000 kg	2500 kg
Load Center		500 mm		
Fork (TxWxL)	B	40x100x1070 mm	45x100x1070 mm	
Fork Adjustable Width	W1	200~970 mm	200~1020 mm	
Lifting Height	H1	3000 mm		
Free Lift		155 mm	155 mm	155 mm
Fork Tilting Angle (F/R)		6° /12°		
Overhead Guard Height	H3	2110 mm		
Turning Radius	R	1830 mm	1960 mm	1960 mm
Inverter		AC Stepless		
Power		Battery		
Tires	Front	6.50-10	6.50-10	24x7-12
	Rear	5.00-8	18x7-8	18x7-8
	No.of tires(F/R)	2/2		
	Material: Rubber	Pneumatic Shaped Soft Solid		
Overall Length (w/o fork)	L1	2050mm	2180 mm	2250 mm
Overall Width	R	1170 mm		
Lifting Speed	Loaded	270 mm/s	240 mm/s	210 mm/s
	Empty	450 mm/s	480 mm/s	480 mm/s
Lowering Speed	Loaded	545 mm/s	535 mm/s	520 mm/s
	Empty	540 mm/s	510 mm/s	480 mm/s
Traveling Speed	Loaded	12 km/h	12 km/h	11 km/h
	Empty	14 km/h	13 km/h	13 km/h
Gradeability	Loaded	18%	18%	18%
	Empty	24%	24%	20%
Weight	Inc. Battery	3250 kg	3450 kg	4030 kg
	Exc. Battery	2550 kg	2650 kg	2900 kg
Min. Width Intersection Aisle		3660 mm	3900 mm	4050 mm
Wheel Base	L	1280 mm	1400 mm	1400 mm
Motor	Drive motor	8 kw AC	10 kw AC	
	Lift Motor (Steering included)	12.0 kw AC	12.0 kw AC	12.0 kw AC
Ground Clearance		95 mm		
Battery(48V/ 5HR)		400 AH	480 AH	560 AH
Charger(48V/3 phases)Max. Current		80 A		

• Optional type & scales for ABF's Masts

Mast Types		H1 Lift height								
		mm								
		3000*	3500	4000	4500	5000	5500	6000	6350	
Duplex mast telescopic	e.Height of mast. min.	H	2030	2280	2530	-	-	-	-	-
	g.Height of mast. max.	H2	3965	4465	4965	-	-	-	-	-
Duplex mast Hi-Lo (Full Free Lift)	e.Height of mast. min.	H	2030	2280	2530	-	-	-	-	-
	g.Height of mast. max.	H2	3965	4465	4965	-	-	-	-	-
	b. Max. free lift.		1520	1770	2020	-	-	-	-	-
Triple stage mast Hi-Lo	e.Height of mast. min.	H	1615	1780	1880	2030	2180	2380	2530	2645
	g.Height of mast. max.	H2	3965	4465	4965	5465	5965	6465	6965	7315
	b. Max. free lift.		995	1045	1370	1535	1690	1865	2045	2120

Note: \* means standard size, the others are optional.  
The fork tilting angle(F/R) for triple stage are 4°/10°

- A strong body construction with steel frame (over 6mm / 1/4") and overhead safeguard ensures the driver's safety.
- The bright-colored coating is composed of a detailed surface treatment, anti-rust-painting, and lead-free PU baked enamel finish. This superior painting process withstands harsh working environments and assures a much longer life.
- Electric-motor power steering (E.P.S.)
- Provides surprisingly-light steering and allows for easy operation in narrow aisles.
- Soft solid tires are standard. It can last 5 years without any service; Very stable, with no right or left movement.
- An adjustable and cushioned seat provides an easy and comfortable ride with seat belt and a safety switch in this seat. A hydraulically activated foot-operated brake guarantees safety. A mechanical hand brake is for parking use.
- Thermo protector for motor, emergency



stop switch, start switch lamp, speed meter, and hydraulic cut-off switch are available as options.

- AC drive motor provides high starting torque and flexible operation.
- A battery charging system with microprocessor & timer control automatically detects battery capacity and cuts off when being fully charged. This shortens the charging time and economizes a longer battery life. This charger can be plugged into 220 / 380 / 440 volts outlet (3 phases).
- Back buzzer is a standard function.
- LCD graphic smart display is an intelligent dashboard connected to the truck system by CAN-BUS line, which provides the operator with an easy information about the status of some truck devices.

# NOVELTEK

## **FBR-10/15/20** **COUNTERBALANCED REACH TRUCK** **(1 TON / 1.5 TONS / 2 TONS)**

- Mast reach electric stacker.
- Advanced ac motor product.
- Without carbon brush, easy maintenance.
- Save electricity efficiently by 30%.
- Lead-free pu baked enamel painting.
- Easy drive steering wheel .
- Mast draw back can reduce truck weight, length and increase stability.
- No pollution, quiet, safty, durable and reliable
- Easy change battery by side move design.
- Electric-motor power steering (E.P.S.) Provides surprisingly-light steering and allows for easy operation in narrow aisles.
- LCD graphic smart display is an intelligent dashboard connected to the truck system by can-bus line. Which provides the operator with a easy information about the status of some truck devices.

Optional items:

-35°C Cold storage version, side shift...Etc. Are available as options.



## FBR-10/15/20 Specifications

MODEL		UNIT	FBR-10	FBR-15	FBR-20
Rated Capacity		kg	1000	1500	2000
Load Center		mm	500		
Overall length (L)		mm	1620	1810	2020
Wheel base (L1)		mm	1240	1436	1644
Overall length extended (E1)		mm	1746	1942	2150
Turning radius (R)		mm	1950	2100	2300
Reach length (V)		mm	500	622	725
Travel speed	Loaded	km/h	8	7.5	7
	Empty	km/h	9		
Lifting speed	Loaded	mm/s	320	300	280
	Empty	mm/s	440		
Gradeability	Loaded		12%		10%
	Empty		20%		
AC motor	Drive	kw/ 48V	4.0		
	Steer	kw/ 48V	0.4		
	Lift	kw/ 48V	12		
Controller	Drive		ACMOS		
	Lift		ACMOS		
Battery (48V)			320		
Wheels/ model			Solid		
Fork wheel	PU		Ø254x114mm x2		
Drive wheel			Ø235x120mm x1		
Balance wheel			Ø130x60mm x2		
Weight (Inc. Battery)			2044	2124	2204

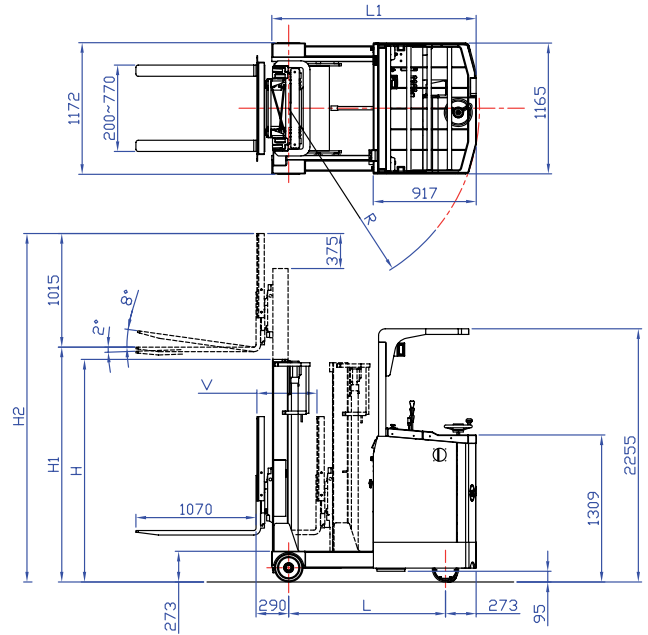

MAST TYPES		MAX. FORK HEIGHT (mm)												
		2000	*2500	2700	3000	3300	3500	3700	4000	4500	5000	5500	6000	6300
DUPLEX MAST TELESCOPIC														
MIN. MAST HEIGHT (N)	H	1610	1860	1960	2110	2260	2360	2460	2610					
MAX. MAST HEIGHT (P)	H2	3060	3560	3760	4060	4360	4565	4760	5065					
DUPLEX MAST HI-LO FULL FREE LIFT														
MIN. MAST HEIGHT (N)	H	1610	1860	-	2110	-	2360	-	2610	-	-	-	-	-
MAX. MAST HEIGHT (P)	H2	3015	3515	-	4015	-	4515	-	5015	-	-	-	-	-
MAX. FREE LIFT		1000	1240	-	1490	-	1740	-	1998	-	-	-	-	-
TRIPLE STAGE MAST HI-LO FULL FREE LIFT														
MIN. MAST HEIGHT (N)	H	-	-	-	1582	-	1832	-	1932	2082	2232	2382	2532	2652
MAX. MAST HEIGHT (P)	H2	-	-	-	4023	-	4523	-	5023	5523	6023	6523	7023	7323
MAX. FREE LIFT		-	-	-	950	-	1000	-	1324	1490	1650	1820	2000	2120

# NOVELTEK

## **ABF-15/20/25 + PAPER ROLL CLAMP** **ADVANCED SIT-ON ELECTRIC FORK LIFT TRUCK+** **PAPER ROLL CLAMP (AC SYSTEM)** **(1.5 TONS / 2 TONS / 2.5 TONS)**

- AC stepless inverter.
- Adjustable and cushion seat with safety switch.
- Soft solid tyres are standard.
- 3 Sets of hydraulic systems: Lifting / tilting / clamping.
- Lead-free PU baked enamel painting.
- A rugged paper roll clamps handle paper rolls of every size to meet clients' unique requirements.



## **ABF-15/20/25+BALE CLAMP**

- Palletless handling of nearly any type of baled product such as cotton, wool, synthetic textile bales, corrugated, newsprint, rag, hay and metal scrap bales translates into savings in time and storage costs.





## ART-10/15/20/ AC+EPS

### ADVANCED COUNTERBALANCED REACH TRUCK (AC SYSTEM) ( 1 TON / 1.5 TONS / 2.0 TONS)



- With EPS (Electronic Power Steering) system, very easy to drive.
- Mast reach electric stacker
- Advanced AC motor product
- Without carbon brush, easy maintenance
- Save electricity efficiently by 30%
- FRP body cover and battery cover
- Lead-free PU baked enamel painting
- Polyoxymethylene Steering Arm
- Mast draw back can reduce truck weight, reduce truck length and increase stability
- With a slow drive speed switch for duplex mast HI-LO (3M or above) and triple stage mast HI-LO (3.5M or above)
- No pollution, quiet, safety, durable and reliable
- Easy change battery by side move design.

#### Optional items:

-35°C cold storage version, foldable side protection guards, side shift, battery change table, shaft type forks, crane...etc. are available as options



Mast at reaching condition  
It can carry any types of pallets.



Mast at draw back condition it can reduce truck weight, reduce truck length and increase stability.

## ★ ART-10/15/20 Specification ★

Item		ART-10	ART-15	ART-20
<b>★Lifting</b>				
Rated capacity		1000 kg	1500 kg	2000 kg
Load center		500 mm		
Forks (T x W x L)		40x100x1070 mm		45x100x1070 mm
Lifting speed	loaded	95 mm/s	105 mm/s	80 mm/s
	empty	180 mm/s	180 mm/s	180 mm/s
Lowering speed	loaded	140 mm/s	140 mm/s	140 mm/s
	empty	140 mm/s	140 mm/s	140 mm/s
Travel speed	loaded	5.5 km/h	5.5 km/h	5.5 km/h
	empty	6 km/h	6 km/h	6 km/h
Gradeability	loaded	8 %		
	empty	18 %		
Fork tilting angle (F/R)		2° / 8°		
Weight of truck	with battery	1830 kg	1860 kg	1880 kg
	without battery	1615 kg	1645 kg	1665 kg
<b>★Wheels</b>				
Fork wheels	dimension	Ø205x70 mm		
	quantity (R/L)	1/1		
	material	PU		
Drive wheel	dimension	Ø235x120 mm		
	material	PU (Rubber is optional )		
<b>★Battery &amp; Motors</b>				
Battery capacity at 5 hours charge rate		240AH / 24V		
Max. charging current(24 V)		40 A		
AC Drive motor power(24 V)		1.6 kw		
Steering motor power(24 V)		0.4 kw		
Lifting motor power(24 V)		3.5 kw		
Controller		AC Stepless		
<b>★Steering &amp; brake</b>				
Steering System		Steering Arm		
Steering arc. total		185 degree		
Traveling	Type	Electromagnetic spring pressure		
	Actuated	Drive wheel		
Parking brake	Type	Electromagnetic spring pressure		
	Actuated	Drive wheel		
Alarm Device	Standard	Reverse buzzer		

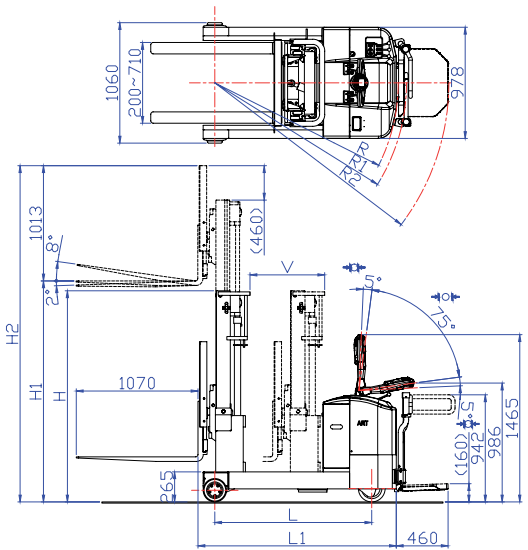

Model		ART-10	ART-15	ART-20
Item		mm	mm	mm
Truck length	L1	1605	1755	1955
Truck width		978		
Wheel base	L	1230	1380	1580
Total length with draw		2233	2235	2339
Over all length extended		2743	2890	3094
Fork length		1070		
Turning Radius	R	1466	1614	1812
Turning Radius	R1	1539	1687	1885
Turning Radius	R2	1910	2060	2259
Mast reach length		510	655	755
Fork wheel width		1060		
Fork adjustable width		200-710		
Height of straddle		265		

MAST TYPES		MAX. FORK HEIGHT (P) (mm)													
		2000	2500	*3000	3500	4000	4500	5000	5500	6000	6350	6500	7000	7200	7500
DUPLIX MAST TELESCOPIC															
MIN. MAST HEIGHT	H	1610	1860	2110	2360	2610	-	-	-	-	-	-	-	-	-
MAX. MAST HEIGHT	H2	3073	3573	4073	4573	5073	-	-	-	-	-	-	-	-	-
DUPLIX MAST HI-LO FULL FREE LIFT															
MIN. MAST HEIGHT	H	1610	1860	2110	2360	2610	-	-	-	-	-	-	-	-	-
MAX. MAST HEIGHT	H2	3025	3565	4065	4565	5070	-	-	-	-	-	-	-	-	-
FREE LIFT		1000	1290	1540	1790	2045	-	-	-	-	-	-	-	-	-
TRIPLE STAGE MAST HI-LO															
MIN. MAST HEIGHT	H	-	-	1610	1860	1960	2110	2260	2460	2610	2730	2860	3070	3120	3220
MAX. MAST HEIGHT	H2	-	-	4025	4575	5100	5565	6025	6595	7070	7425	7565	8060	8260	8560
FREE LIFT		-	-	1000	1050	1374	1540	1698	1870	2048	2170	2150	2350	2450	2550

· Lifting height over 6500mm, ART-20 length + 150mm ; width + 165mm

- AC Drive Motor
- With AC drive motor can save electricity efficiently by 30% and carbon brushless, easy maintenance. When Steering Arm is vertical or horizontal, the micro sensor is off and the spring electromagnetic pressure works to brake the truck.

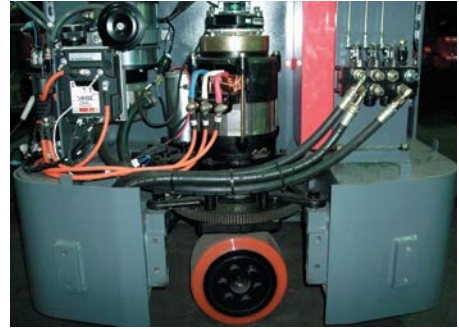

- EPS Steering Arm (Electronic Power Steering)
- Steering Arm can work in 185 degree total arc for extra convenience. Easy-reach buttons for lifting and lowering and the horn are placed in the middle of the Steering Arm. For safety sake, the red colour safety device on top of steering handle, once the operator touches it, the truck will drive to forward direction.



- LED MDI-CAN multifunctional indicator has many internal functions:  
Indication of battery's state of charge.  
Operating hour meter.  
With CANBUS system, low battery protection alarm and shows all trouble coding for easy service use.

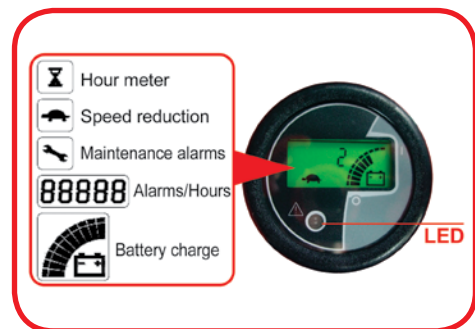

- Powerful Traction Battery
- Traction Battery used in the truck endures about 5 years and can be operated normally for 8 hours after 8 hours charge.
- Use Germany Hoesch brand section steel to make the high safety mast.
- With bright colored coating composed of a detailed surface treatment, anti-rust primer, and lead-free PU baked enamel painting. This superior painting process withstands harsh working environments assures a much longer life.
- With emergency stop switch for safety use.
- With grounding chain with PU drive wheel.

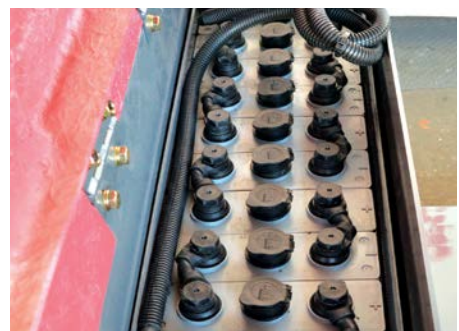

# NOVELTEK

## ACS-08/10/12/15 AC + EPS

### ADVANCED COUNTERBALANCED WALKIE STACKER (AC SYSTEM) (800KG / 1.0TON / 1.2 TONS / 1.5TONS)

- Electronic Power Steering system (EPS system) very easy to drive
- Advanced AC motor product
- Without carbon brush, reduce service cost
- Save electricity efficiently by 30%
- FRP body cover and battery cover
- Lead-free PU baked enamel coating
- Polyoxymethylene Steering Arm
- No pollution, quiet, safety, durable and reliable
- Adjustable forged forks suitable for any pallets
- Use Germany Hoesch brand section steel to make the high safety mast.
- It can be operated in 2.7 meter width aisle for ACS-08/10
- Back buzzer is a standard function
- Max. fork lifting height between 2 meter and 6 meter
- With a slow drive speed switch for duplex mast HI-LO (3m or above) and triple stage mast HI-LO (3.5M or above)
- With grounding chain with PU drive wheel.
- Easy change battery by side move design.



#### Optional items:

Triple stage, full free lift mast, -35°C cold storage version, foldable side protection guards, shaft type forks, side shift, battery change table...etc. are available as options

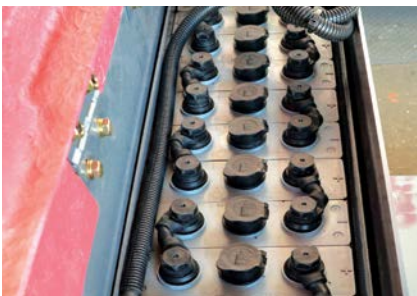

· Powerful Traction Battery



· EPS Steering Arm



· AC Drive motor

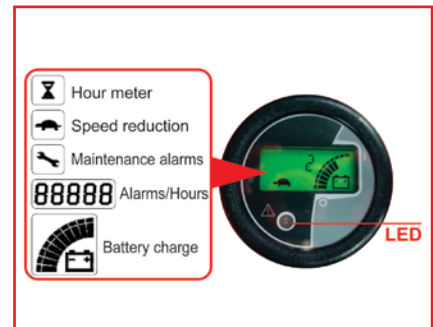

· LED MDI-CAN multifunctional indicator

## ★ ACS-08/10 Specification ★

MODEL		ACS-08	ACS-10
Capacity		800kg	1000kg
Load center		500 mm	
Fork length (T x W x L)		40x100x1070 mm	
Lifting speed	loaded	97 mm/s	97 mm/s
	empty	130 mm/s	
Lowering speed	loaded	152 mm/s	
	empty	160 mm/s	
Travel speed	loaded	5.5 km/h	
	empty	6 km/h	
Gradeability	loaded	9 %	
	empty	24 %	
Fork tilting (F/R)		2° / 8°	
Fork wheels	dimension	Ø205x70 mm	
	quantity (R/L)	1/1	
	material	PU	
Drive wheel	dimension	Ø235x120 mm	
	material	Rubber ( PU is optional )	
Battery capacity at 5 hours charge rate		240 AH / 24 V	
Max. charging current (24 V)		40 A	
AC Drive motor power (24 V)		1.6 kw	
Steering motor power (24 V)		0.4 kw	
Lifting motor power (24 V)		2.5 kw	
Inverter		AC Stepless	
Steering & brake			
Steering system		Steering Arm	
Steering arc. total		185 degree	
Traveling brake	Type	Electromagnetic spring pressure	
	Actuated	Drive wheel	
Parking brake	Type	Electromagnetic spring pressure	
	Actuated	Drive wheel	
Alarm Device	Standard	Back buzzer	
Weight (with battery)(240 AH)		1392 kg	1542 kg

Mast type	Max. Fork height (mm) (M)			
Duplex mast telescopic	2000	*2500	3000	3500
Min. Mast height (N)	1500	1750	2000	2250
Max. Mast height (P)	2800	3300	3800	4300

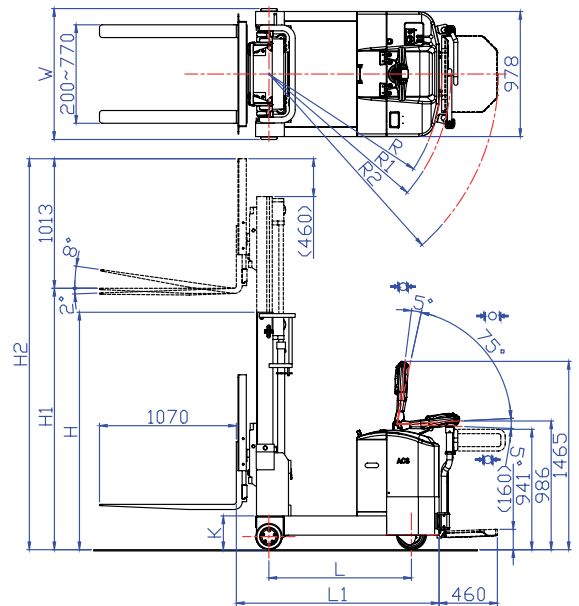

Model		ACS-08	ACS-10
Item		mm	mm
Truck length	L1	1437	1557
Truck width		978	
Wheel base	L	1011	1131
Fork Length		1070	1070
Turning Radius	R1	1323	1441
Turning Radius	R2	1692	1811
Fork outer width	H	200-770	
Fork wheel width	W	902	1025
Height of straddle		257	265
Height of steering arm		1465	

## ★ ACS-12/15 Specification ★

MODEL		ACS-12	ACS-15
Capacity		1200kg	1500kg
Load center		500 mm	
Fork length (T x W x L)		40x100x1070 mm	
Lifting speed	loaded	110 mm/s	90 mm/s
	empty	150 / 200 mm/s	
Lowering speed	loaded	180 mm/s	
	empty	90 / 160 mm/s	
Travel speed	loaded	5.5 km/h	
	empty	6 km/h	
Gradeability	loaded	9 %	
	empty	24 %	
Fork tilting (F/R)		2° / 8°	
Fork wheels	dimension	Ø205x70 mm	
	quantity (R/L)	1/1	
	material	PU	
Drive wheel	dimension	Ø235x120 mm	
	material	Rubber ( PU is optional )	
Battery capacity at 5 hours charge rate		240 AH / 24 V	
Max. charging current(24 V)		40 A	
AC Drive motor power(24 V)		1.6 kw	
Steering motor power(24 V)		0.4 kw	
Lifting motor power(24 V)		3.5 kw	
Inverter		AC Stepless	
Steering & brake			
Steering system		Steering Arm	
Steering arc. total		185 degree	
Traveling brake	Type	Electromagnetic spring pressure	
	Actuated	Drive wheel	
Parking brake	Type	Electromagnetic spring pressure	
	Actuated	Drive wheel	
Alarm Device	Standard	Back buzzer	
	Weight (with battery)(240 AH)		1910kg

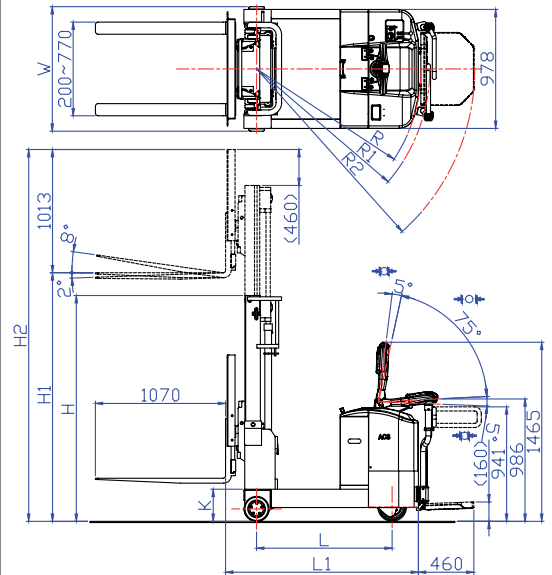

Model		ACS-12	ACS-15
Item		mm	mm
Truck length	L1	1705	1935
Truck width	W	978	
Wheel base	L	1235	1465
Turning Radius	R	1467	1696
Turning Radius	R1	1542	1769
Turning Radius	R2	1914	2143
Fork outer width		200-770	
Fork wheel width		902	1025
Height of straddle		257	265
Height of steering arm		1465	

MAST TYPES	MAX. FORK HEIGHT (mm)									
	DUPLEX MAST TELESCOPIC	2000	*2500	3000	3500	4000	4500	5000	5500	6000
MIN. MAST HEIGHT (N)	1610	1860	2110	2360	2610	-	-	-	-	-
MAX. MAST HEIGHT (P)	3073	3573	4073	4573	5073	-	-	-	-	-
DUPLEX MAST HI-LO FULL FREE LIFT										
MIN. MAST HEIGHT (N)	1610	1860	2110	2360	2610	-	-	-	-	-
MAX. MAST HEIGHT (P)	3025	3565	4065	4565	5070	-	-	-	-	-
MAX. FREE LIFT	1000	1290	1540	1790	2045	-	-	-	-	-
TRIPLE STAGE MAST HI-LO FULL FREE LIFT										
MIN. MAST HEIGHT (N)	-	-	1610	1860	1960	2110	2260	2460	2610	2730
MAX. MAST HEIGHT (P)	-	-	4025	4575	5100	5565	6025	6595	7070	7425
MAX. FREE LIFT (L)	-	-	1000	1050	1374	1540	1698	1870	2048	2170

## APS-10/15/18/20 AC ADVANCED POWERED PALLET STACKER (AC SYSTEM) (1 TON / 1.5 TONS / 1.8 TONS / 2 TONS)

- Advanced AC motor truck.
- Suspension drive motor allowing to use the truck on uneven surfaces.
- Without carbon brush, easy maintenance.
- With AC vectorial stepless inverter.
- 30% battery efficiency improvement.
- Quiet, and safe operation.
- Environmental-friendly, durable, reliable truck.
- Electric drive, electric lifting.
- Lead-free PU baked enamel painting.
- Straddle can lift 200mm. This stacker can carry 2 pieces of european open pallets at same time. It also has higher gradeability.
- Body length is 855mm only.
- Ride-on drive, easy handling.
- It can turn in 2.1 meter wide aisle.
- Max. fork lifting height between 2 meter and 6 meter
- With a slow drive speed switch for duplex mast HI-LO (3m or above) and triple stage mast HI-LO (3.5M or above)
- Triple stage, full free lift mast and -35°C cold storage version...etc. are available as options.



Triple Stage Masts



Fixed Straddle



Straddle Lifting

# NOVELTEK

- Interior-mounted Cushion Absorbers lessen wobbling and prove extra steadiness. When loaded, specially designed hydraulic-mechanical system balances the weight to castor wheels and drive wheel, making Steering Arm light to control, yet enough to turn and climb.

- The driving wheel can be moved up and down by 45 mm. It can be driven over the rise high and depression within 45 mm.

- ★Polyoxymethylene tiller head provides a 185 degree steer angle. A red safety button ensures the truck drives forward for the improved safety-industrial machinery directive.

- ★With AC Vectorial Stepless MOSFET inverter effectively provides more progressive acceleration, stable operation and consumes less electricity.

- Use Germany Hoesch brand section steel to make the high safety mast.

- The bright colored coating is composed of a detailed surface treatment, anti-rusting primer, and lead-free PU baked enamel painting.

- This superior painting process withstands harsh working environments and assures a much longer life.

- Firmly-welded steel frame is constructed to preserve structural integrity even upon sustaining super weight.

- All electrically powered driving and lifting not only save manpower and time, but also keep working environments quiet and clean.

- This is an environment-friendly product.

- Castor Wheel under each side of the truck increases balance and prevents turnover as well. 2 / 2 Tandem Fork Wheels (Ø83mm / 3.27") fitted on straddle. It can carry more load without damage.

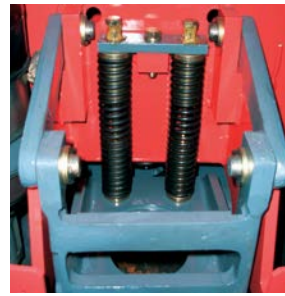

Option: Digital weight scale

### OPTIONAL SPECIFICATION:

- A : Overall fork width 470/520/685mm
- C : Fork inner width 90/140/305mm
- D : Fork length 1000/1300/1450mm
- E : Front end length 250/400mm

Model(APS)		10	15	18	20
Item		mm	mm	mm	mm
Overall fork width	W1	580	580	580	580
Each fork width	W2	190	190	190	200
Fork inner width	W3	200	200	200	180
Fork length	B	1150	1150	1150	1150
Overall truck width	W	850	850	850	850
Length of body	L1	795	815	815	815
	L2	855	875	875	875
	L3	1235	1255	1255	1255
Turning radius	R	1620	1630	1630	1630
	R1	1680	1690	1690	1690
	R2	2060	2070	2070	2070
Min. fork height	h	90	90	90	90
Straddle lift	h1	None	205	205	205
Each straddle width		150	150	150	150
Straddle outer width		540	540	540	540
Straddle inner width		240	240	240	240

Mast Types	Max. fork height(M) mm								
	APS-10/15/18/20				APS-15/18/20				
	2000	2500	3000	3500	4000	4500	5000	5500	6000
Duplex mast telescopic									
Min. mast height	H	1540	1790	2040	2290	2540	--	--	--
Max. mast height	H2	2500	3000	3580	4080	4580	--	--	--
Duplex mast Hi-Lo									
Min. mast height	H	1510	1760	2010	2260	2510	--	--	--
Max. mast height	H2	2500	3000	3580	4080	4580	--	--	--
Free lift	H4	990	1280	1530	1780	2040	--	--	--
Triple stage mast Hi-Lo									
Min. mast height	H	--	--	1510	1760	1860	2010	2160	2360
Max. mast height	H2	--	--	3580	4080	4580	5080	5580	6080
Free lift	H4	--	--	990	1040	1360	1530	1690	1860

\* These mast types are not available for APS-10.



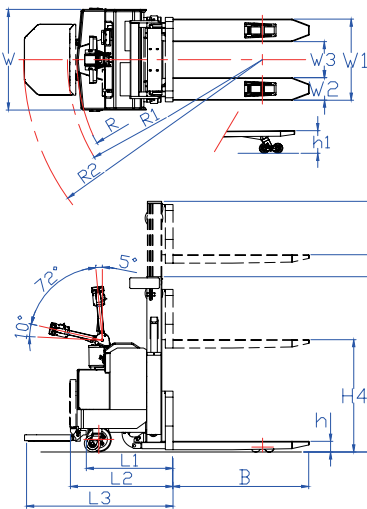

★ A 1.8 kw AC induction motor filed with an electromagnetic brake. It provides excellent dynamic performance. Fully laden the vehicle achieves a very good 9% grade ability. With the tiller head being in vertical or horizontal position, an electromagnetic brake will hold the truck.

- AC vectorial stepless MOSFET inverter is fitted with AC drive motor of 1.8kw/ 24v.
- Back buzzer is a standard function.

### ★ APS-10/15/18/20 Specifications ★

Item		APS-10	APS-15	APS-18	APS-20
<b>★ Lifting</b>					
Rated capacity		1000 kg	1500 kg	1800 kg	2000 kg
Load center		600 mm			
Max.lifting speed	empty	140 mm/s	156 mm/s	150 mm/s	150 mm/s
	loaded	110 mm/s	100 mm/s	90 mm/s	100 mm/s
Max.lowering speed	empty	110 mm/s	170 mm/s	170 mm/s	60 mm/s
	loaded	570 mm/s	300 mm/s	300 mm/s	300 mm/s
<b>★ Driving</b>					
Travel speed	empty	6.0 km/h			
	loaded	5.5 km/h			
Gradeability	empty	16 %	16 %	16 %	16 %
	loaded	9%	9%	9%	9%
<b>★ Weight of truck</b>					
Service weight	with battery 240 Ah	998 kg	1025 kg	1042 kg	1080 kg
	without battery	783 kg	810 kg	827 kg	865 kg
<b>★ Wheels</b>					
Fork wheels	dimension	ø83x90 mm	ø83x75 mm	ø83x75 mm	ø83x75 mm
	quantity(R/L)	1/1	2/2	2/2	2/2
	material	PU			
Castor wheels	dimension	ø140x60mm			
	quantity(R/L)	1/1			
	material	PU			
Drive wheel	dimension	ø212x70mm			
	material	Standard:Rubber/Opt. PU			
	movement up	15 mm			
	movement down	30 mm			
<b>★ Battery and motors</b>					
Battery capacity at 5 hours discharge rate		180AH/24V	240AH/24V	240AH/24V	240AH/24V
Max. charging current		30A/24V	40A/24V	40A/24V	40A/24V
Drive motor power (AC)		1.8 kw/24V			
Lift motor power		2.0 kw/24V	3.0 kw/24V	3.0 kw/24V	3.0 kw/24V
Inverter	Travelling	AC Stepless			
	Lifting	Contactor type			
<b>★ Steering &amp; Brake</b>					
Steering system		Steering Arm			
Steering arc. total		185 degree			
Travelling brake	type	Electromagnetic spring pressure			
Parking brake	type	Electromagnetic spring pressure			
	actuated part	Drive wheel			
Parking brake	type	Electromagnetic spring pressure			
	actuated part	Drive wheel			



- Riding on the handy platform avoids haste in catching up with the truck and reduces physical fatigue.

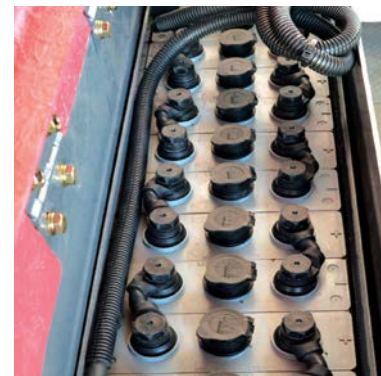

- Traction Battery used in the truck endures about 5 years and can be operated normally for 8 hours after 8 hours charge.

Optional items:

- Foldable side protection guards, Longer steering handle, Forged type forks, Stopper for ride-on platform, Removable back rest, -35°C cold Storage type, Adjustable straddle lift, Cable control lifting, Non-marking white rubber drive wheel, Vulcollan drive wheel, DC drive motor & controller ...etc.

## APS-15/18/20 AC+EPS ADVANCED POWERED PALLET STACKER (AC+EPS) (1.5 TONS / 1.8 TONS / 2 TONS)

- Electronic Power Steering system (EPS system) very easy to drive.
- While turning steering, the drive speed lowering down automatically by 50%.
- With AC driving motor, it can save electricity efficiently by 30% at least, and carbon brushless equipped for easier maintenance.
- Latest AC inverter circuit control system brings stability, power saving, calmness and cleanliness.
- Use Germany HOESCH brand section steel to make the high safety mast.
- Lead- free PU baked enamel painting.
- Max. fork lifting height between 2 meter and 6 meter.
- Straddle can lift 205mm. This stacker can carry 2 pieces of European open pallets at the same time. The driving wheel can move up and down by 45mm.
- Customization for clients' requirements.



### OPTIONAL SPECIFICATION:

- A: Overall fork width 470/ 520/ 685mm
- C: Fork inner width 90/ 140/ 305 mm
- D: Fork length 1000/ 1300/ 1450 mm
- E: Front end length 250/ 400 mm

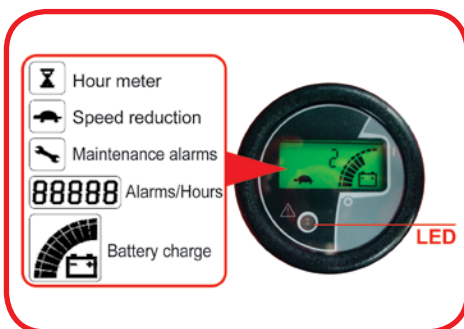

- LED MDI-CAN multifunctional indicator has many internal functions:  
Indication of battery's state of charge.  
Operating hour meter.  
With CANBUS system, low battery protection alarm and shows all trouble coding for easy service use.



- EPS Steering Arm (Electronic Power Steering)
- Steering Arm can work in 185 degree total arc for extra convenience. Easy-reach buttons for lifting and lowering and the horn are placed in the middle of the Steering Arm. For safety sake, the red colour safety device on top of steering handle, once the operator touches it, the truck will drive to forward direction.

## APS-15/18/20 AC+EPS Specifications

Item			APS-15	APS-18	APS-20
<b>Lifting</b>					
Rated capacity	kg		1500	1800	2000
Load center	mm		600		
Lifting speed	empty	mm/s	130	120	100
	loaded	mm/s	100	90	70
Lowering speed	empty	mm/s	170		
	loaded	mm/s	300		
<b>Driving</b>					
Traveling speed	empty	km/h	6.0		
	loaded	km/h	5.5		
Gradeability	empty	%	16%		
	loaded	%	9%		
Service weight	with battery	kg	1080	1160	1160
	without battery	kg	900	945	945
<b>Wheels</b>					
Fork wheels	dimension	mm	Ø83×75mm		
	quantity (R/L)		2/2		
	material		PU		
Castor wheels	dimension	mm	Ø140 x 60 mm		
	quantity (R/L)		1/1		
	material		PU		
Drive wheel	dimension	mm	Ø235×120mm		
	material		PU (rubber is optional)		
	movement up	mm	20	20	20
	movement down	mm	25	25	25
<b>Battery and motors</b>					
Battery capacity at 5 hours charge rate	AH/5HR		184AH/24V	240AH/24V	240AH/24V
Max. charging current (24V)	A		30	40	40
AC drive motor power (24V)	KW		1.6	1.6	1.6
Lifting motor power (24V)	KW		3.0	3.0	3.0
Controller			AC stepless		
<b>Steering &amp; brake</b>					
Steering system			Steering arm		
Steering arc. Total			185 degree		
Parking brake	Type		Electromagnetic spring pressure		
	Actuated		Driving wheel		
Alarm device			Standard reverse buzzer		

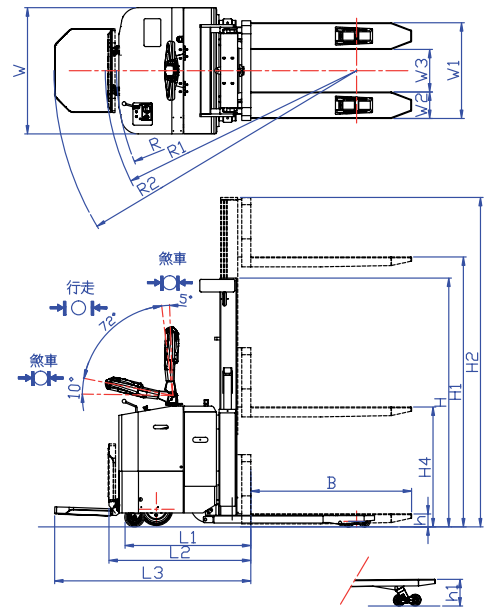

APS+EPS		15	18	20
Item		mm	mm	mm
Fork width	W1	685		
Each fork width	W2	190	200	
Fork inner width	W3	305	285	
Fork length	B	1150		
Overall truck width	W	902		
Length of body	L1	925		
	L2	1040		
	L3	1435		
Turning radius	R	1710		
	R1	1775		
	R2	2115		
Min. fork height	h	90		
Straddle lift	h1	205		
Each straddle width	-	150		

MAST TYPES		MAX. FORK HEIGHT(mm)								
		APS+EPS-15/18/20					APS+EPS-15/18/20			
		2000	2500	3000	3500	4000	4500	5000	5500	6000
<b>DUPLEX MAST TELESCOPIC</b>										
MIN. MAST HEIGHT	H	1540	1790	2040	2290	2540	-	-	-	-
MAX. MAST HEIGHT	H2	2500	3000	3500	4000	4500	-	-	-	-
<b>DUPLEX MAST HI-LO FULL FREE LIFT</b>										
MIN. MAST HEIGHT	H	1510	1760	2010	2260	2510	-	-	-	-
MAX. MAST HEIGHT	H2	2500	3000	3500	4000	4500	-	-	-	-
FREE LIFT	H4	900	1280	1530	1780	2040	-	-	-	-
<b>TRIPLE STAGE MAST HI-LO</b>										
MIN. MAST HEIGHT	H	-	-	1510	1760	1860	2010	2160	2360	2510
MAX. MAST HEIGHT	H2	-	-	3580	4080	4580	5080	5580	6080	6580
FREE LIFT	H4	-	-	990	1040	1360	1530	1690	1860	2040

## PPS-10/15/18/20 POWERED PALLET STACKER (1 TON / 1.5 TONS / 1.8 TONS / 2 TONS)

Option: Forged fork

- Ride-on drive, easy handling.
- Quiet, safety, durable, reliable.
- No pollution.
- Lead-free PU baked enamel painting.
- Electric drive, electric lifting.
- Straddle can lift 200mm. This stacker can carry 2 pieces of european open pallets at same time. It also has higher gradeability.
- Body length is 855mm only.
- It can turn in 2.1 meter wide aisle.
- With a slow drive speed switch for duplex mast HI-LO (3M or above) and triple stage mast HI-LO (3.5M or above)
- Max. fork lifting height between 2 meter and 6 meter, triple stage, full free lift mast, -35°C cold storage version...etc. are available as options.



Straddle lifting



Fixed straddle

- Interior-mounted Cushion Absorbers lessen wobbling and prove extra steadiness. When loaded, specially designed hydraulic-mechanical system evens the weight to castor wheels and drive wheel, making Steering Arm light to control, yet enough to turn and climb.

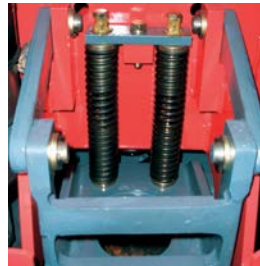

Option: Digital weight scale

- The drive wheel can be moved up and down by 45 mm. The drive wheel can be driven over the rise high and depression with-in 45 mm.



Option: Overhead guard

- Exceptional stepless MOSFET controller effectively provides progressive acceleration, stable operation and consumes less electricity. Resistance-3 controller is also available.

- Use Germany Hoesch brand section steel to make the high safety mast.

- The bright colored coating is composed of a detailed surface treatment, antirusting primer, and lead-free PU baked enamel painting.

This superior painting process withstands harsh working environments and assures a much longer life.

- Firmly-welded steel frame is constructed to preserve structural integrity even upon sustaining super weight.

- All electrically powered driving and lifting not only save manpower and time, but also keep working environments quiet and clean.

- This is a green product.

- Castor wheel under each side of the truck increases balance and prevents turnover as well.

- 2 / 2 Tandem fork wheels(Ø85 mm/3.35") fitted on straddle. It can carry more load without damage.

### OPTIONAL SPECIFICATION:

A : Overall fork width 470/520/685mm

C : Fork inner width 90/140/305mm

D : Fork length 1000/1300/1450mm

E : Front end length 250/400mm

Model(PPS)	10	15	18	20	
Item	mm	mm	mm	mm	
Overall fork width W1	580				
Each fork width W2	190	190	190	200	
Fork inner width W3	305	305	305	285	
Fork length B	1150				
Overall truck width W	850				
Length of body	L1	795	815	815	815
	L2	855	875	875	875
	L3	1235	1255	1255	1255
Turning radius	R	1620	1630	1630	1630
	R1	1680	1690	1690	1690
	R2	2060	2070	2070	2070
Min. fork height h	90				
Straddle lift h1	None	205	205	205	
Each straddle width	150				
Straddle outer width	540				
Straddle inner width	240				

Mast Types	Max. fork height(M) mm								
	PPS-10/15/18/20				PPS-15/18/20				
	2000	2500	3000	3500	4000	4500	5000	5500	6000
Duplex mast telescopic									
Min. mast height H	1540	1790	2040	2290	2540	--	--	--	--
Max. mast height H2	2500	3000	3500	4000	4500	--	--	--	--
Duplex mast Hi-Lo	*	*	*	*					
Min. mast height H	1510	1760	2010	2260	2510	--	--	--	--
Max. mast height H2	2500	3000	3500	4000	4500	--	--	--	--
Max. free lift H4	990	1280	1530	1780	2040	--	--	--	--
Triple stage mast Hi-Lo			*	*					
Min. mast height H	--	--	1510	1760	1860	2010	2160	2360	2510
Max. mast height H2	--	--	3580	4080	4580	5080	5580	6080	6580
Max. free lift H4	--	--	990	1040	1360	1530	1690	1860	2040

\* These mast types are not available for PPS-10.

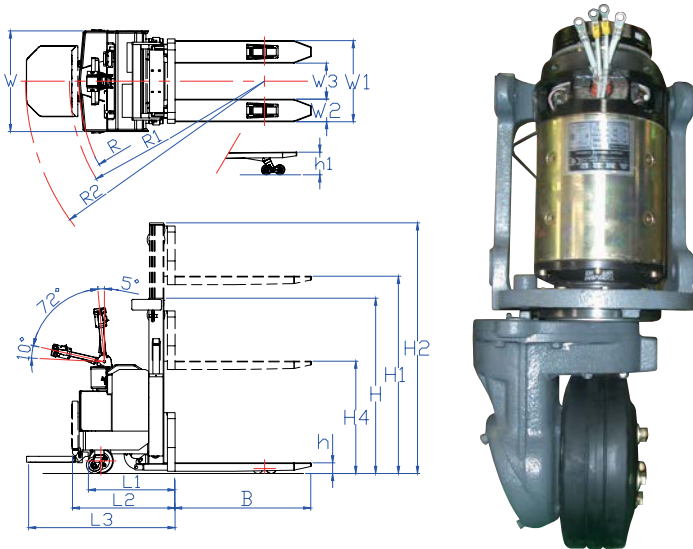

## ★ PPS-10/15/18/20 Specifications ★

Item		PPS-10	PPS-15	PPS-18	PPS-20
★ Lifting					
Rated capacity		1000 kg	1500 kg	1800 kg	2000 kg
Load center		600 mm	600 mm	600 mm	600 mm
Max.lifting speed	empty	140 mm/s	156 mm/s	150 mm/s	150 mm/s
	loaded	110 mm/s	100 mm/s	90 mm/s	70 mm/s
Max.lowering speed	empty	110 mm/s	170 mm/s	170 mm/s	60 mm/s
	loaded	300 mm/s	300 mm/s	300 mm/s	300 mm/s
★ Driving					
Travel speed	empty	6.0 km/h	6.0 km/h	6.0 km/h	6.0 km/h
	loaded	5.0 km/h	5.0 km/h	5.0 km/h	5.0 km/h
Gradeability	empty	16 %	16 %	16 %	16 %
	loaded	9 %	9 %	9 %	9 %
★ Weight of truck					
Service weight	with battery 240 Ah	690 kg	1025 kg	1042 kg	1080 kg
	without battery	783 kg	810 kg	827 kg	865 kg
★ Wheels					
Fork wheels	dimension	ø83x90 mm	ø83x75 mm	ø83x75 mm	ø83x75 mm
	quantity(R/L)	1/1	2/2	2/2	2/2
	material	PU			
Castor wheels	dimension	ø140x60mm	ø140x60mm	ø140x60mm	ø140x60mm
	quantity(R/L)	1/1	1/1	1/1	1/1
	material	PU			
Drive wheel	dimension	ø212x70mm	ø212x70mm	ø212x70mm	ø212x70mm
	material	RUBBER / PU-Optional			
	movement up	15 mm	15 mm	15 mm	15 mm
	movement down	30 mm	30 mm	30 mm	30 mm
★ Battery and motors					
Battery capacity at 5 hours discharge rate		180AH/24V	240AH/24V	240AH/24V	240AH/24V
Max. charging current		30A/24V	40A/24V	40A/24V	40A/24V
DC Drive motor power		1.5 kw/24V	1.5 kw/24V	1.5 kw/24V	1.5 kw/24V
Lift motor power		2.0 kw/24V	3.0 kw/24V	3.0 kw/24V	3.0 kw/24V
Speed control principle-number of steps (Electronic Mosfet stepless is standard, 3-speed is optional.)		Stepless	Stepless	Stepless	Stepless
		Resistance-3 (option)	Resistance-3 (option)	Resistance-3 (option)	Resistance-3 (option)
★ Steering & Brake					
Steering system		Steering Arm			
Steering arc. total		185 degree			
Travelling brake	type	Electromagnetic spring pressure			
	actuated part	Drive wheel			
Parking brake	type	Electromagnetic spring pressure			
	actuated part	Drive wheel			

1500 Watt Drive Motor provides ample load carrying capacity. Even when fully loaded, the gradient ability still reaches 9%. And special brake system is installed as well. When Steering Arm is operated vertically or horizontally, the micro-sensor is off automatically and the spring electromagnetic pressure works to brake the truck.

Optional items:  
 Foldable side protection guards, Longer steering handle, Forged type forks, Stopper for ride-on platform, Removable back rest, -35°C cold storage type, Adjustable straddle lift, Cable control lifting, Non-marking white rubber drive wheel, Vulcollan drive wheel,...etc.

Electric MOSFET stepless controller is fitted with sepex drive motor of 1.5kw/24v.



Riding on the handy platform avoids haste in catching up with the truck and reduces physical fatigue.



Traction Battery used in the truck endures about 5 years and can be operated normally for 8 hours after 8 hours charge.

## PPS-10W/15W/18W/20W POWERED PALLET STACKER (WIDE STRADDLE VERSION) (1 TON / 1.5 TONS / 1.8 TONS / 2 TONS)



- Wide straddle version and forged fork, suitable for any pallets.
- Straddle wheel 150mm(5.9") or 85mm (3.3") diameters are available for your choice.
- Lifting height: from 2 meters (78.7") to 6 meters (236.2"), triple stage HI-LO is optional.
- With a slow drive speed switch for duplex mast HI-LO (3M or above) and triple stage mast HI-LO (3.5M or above)
- -35°C cold storage type and special attachments are optional.
- Any width of straddle size can be produced to meet customers' requirement specifications.
- Leadless painting

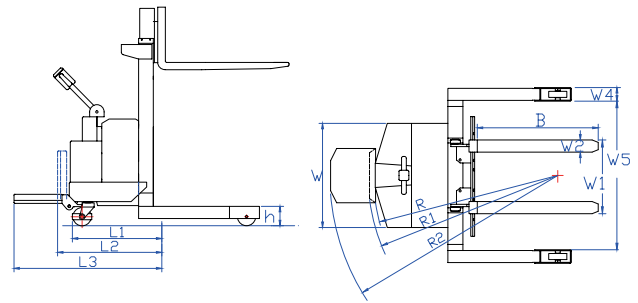

DESCRIPTION		mm
Load center		600
Fork outer width	W1	200-800
Straddle inner width	W5	Palletwidth+100
Each fork width	W2	100
Fork length	B	1070
Body width	W	850
Body length	L1	795
	L2	855
	L3	1235
Turning radius	R	1569
	R1	1620
	R2	1989
Straddle height	h	150 or 85
Each straddle width	W4	85 or 150

OPTIONAL SPECIFICATION	
Straddle outer width :	1300mm, 1400mm
Fork length :	900mm, 1070mm, 1220mm
Straddle wheels to Front end of forks :	250mm, 400mm

## TTL-30/50 LIFTING TOW TRUCK (DC SYSTEM) (3 TONS / 5 TONS)

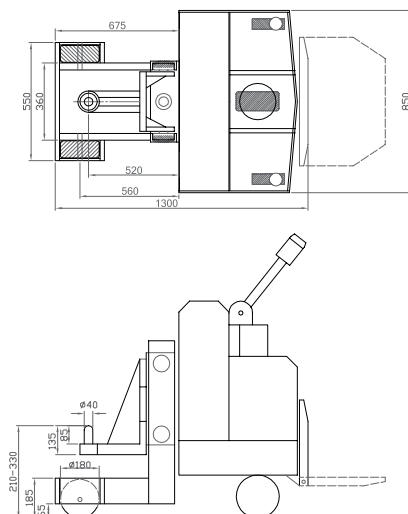

Item	TTL-50
Towing capacity	5000 kg
Lifting capacity	2500 kg
Lifting height	210-330 mm
Truck length	1300 mm
Truck width	850 mm
Truck height	1400 mm
Speed control	Stepless
Brake	Electromagnetic spring pressure
Drive motor	1.5 kw/24V
Drive wheel	Ø212x70 mm
Castor wheel	Ø140x60 mm
Fork wheel	Ø150x50 mm
Battery	240AH/24V
Truck weight	800 kg
Hook Type	Customer's special requirement dimensions are welcome to produce. Hour meter and back buzzer, special towing hook ...etc. are optional.

## APT-20/25/30 AC

**ADVANCED POWERED PALLET TRUCK (AC SYSTEM)**  
**(2.0 TONS / 2.5 TONS / 3 TONS)**



- Advance AC motor truck.
- Brushless , reduce service cost
- With flux AC inverter
- 30% Battery efficiency improvement.
- Hidden caster wheels, improve safety
- Suitable for both open and closed pallets
- Suspension drive motor allowing to use the truck on uneven surfaces.
- Quiet, and safe operation.
- Environmentally, friendly, durable, reliable truck.
- Electric drive, electric lifting.
- This truck has cold version for -35°C cold storage use.
- Lead-free PU baked enamel painting.



Microprocessor charger with equalizing function



Roller Carrier Truck



## APT-20/25/30 AC Specifications

Item	APT-20	APT-25	APT-30
<b>*Lifting</b>			
Rated capacity	2000kg	2500kg	3000kg
Load center	600mm		
Lifting speed	empty	2.0sec	
	loaded	2.5sec	3.0sec
Lowering speed	empty	2.0sec	
	loaded	1.9sec	2.0sec
Travel speed	empty	6.0km/h	
	loaded	5.5km/h	
Gradeability	empty	18%	
	loaded	8%	
Weight (W/O battery)	480kg		490kg
<b>*Wheels</b>			
Fork wheels	dimension	ø83 x 75mm(Standard)	
	quantity(R/L)	2 / 2	
	material	PU	
	dimension	ø83 x 90 mm	
	quantity(R/L)	1 / 1	
	material	PU	
Caster wheels	dimension	ø140 x 60mm	
	quantity(R/L)	1 / 1(R/L)	
	material	PU	
Drive wheel	dimension	ø212 x 70 mm	
	material	Standard	Rubber
		Optional	PU
	Movement up	15mm	
	Movement down	30mm	
<b>*Battery &amp; Motors</b>			
Battery capacity at 5 hours discharge rate	180AH / 24V Traction battery	240AH / 24V Traction battery	
	Other options are available		
Max. charging current	30A / 24V	40A / 24V	
AC Drive motor power	1.8kw / 24V		
Lift motor power	2.5kw / 24V		
Inverter	Travelling	AC Stepless	
	Lifting	Contactor type	
<b>*Steering &amp; Brake</b>			
Steering system	Steering arm		
Steering Arc. total	185 degrees		
Travelling brake	Type	Electromagnetic spring pressure	
	Actuated part	Drive wheel	
Parking brake	Type	Electromagnetic spring pressure	
	Actuated part	Drive wheel	

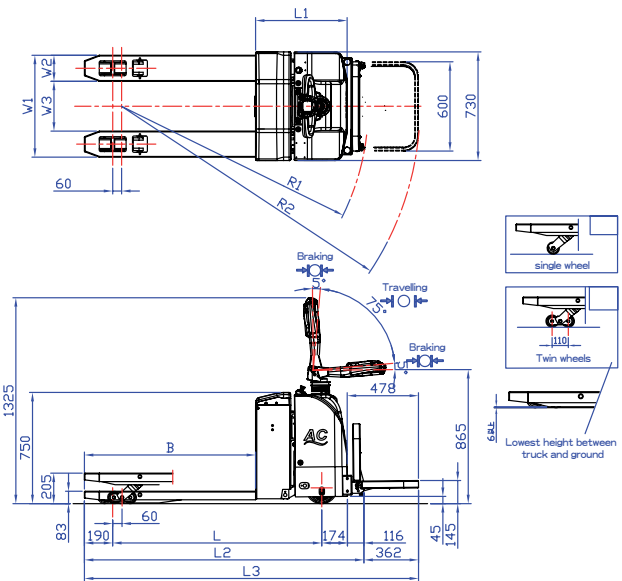

Model		APT-20	APT-25	APT-30
Item		mm	mm	mm
Overall fork width	W1	580		
Each fork width	W2	175		
Fork inner width	W3	335		
Fork length	B	1150		
Max. fork height		205		
Min. fork height		83		
Overall height		1325		
Overall length	L1	620	620	695
Overall width		730		
Overall length sub step is folded	L2	1886	1961	
Overall length sub step is opened	L3	2248	2323	
Wheel base	L	1406	1481	
Min. turning radius	R1	1658	1733	
Max. turning radius	R2	2005	2078	
Distance of fork wheels		110		
Distance from center of fork wheels to the front of fork		190		
When the forks are at the lowest				
When the forks are at the highest		205		
Platform	Length	478		
Platform	Width	600		
Height of platform to ground	H	145		
Height of platform to ground	L	45		
Distance from battery to ground		750		

### Optional items:

Foldable side protection guards, Longer steering handle, Stopper for ride-on platform, Removable back rest, -35°C cold storage type, 65mm low profile fork height, and 75mm middle profile fork height, Non-marking white rubber drive wheel, Polyurethane drive wheel, Hydraulic restrictor valve(reduce lowering speed), DC drive motor & controller...etc.

### OPTIONAL SPECIFICATIONS:

W1: Overall fork width	470mm/18.50"	520mm/20.47"	685mm/27"
W2: Fork inner width	120mm/4.72"	170mm/6.69"	335mm/13.19"
L : Fork length	1000mm/39.37"	1300mm/51.18"	1450mm/57.09"

# NOVELTEK



- A Novelttek Traction Battery provide with the APT pallet truck ensure a full (8 hours) shift to drive cycle.

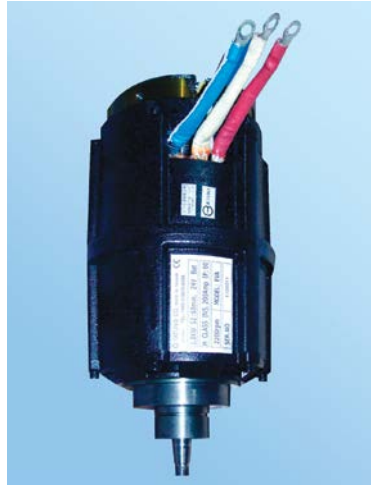

- A 1.8 kw AC induction motor filed with an electromagnetic brake. It provides excellent dynamic performance. Fully laden the vehicle achieves a very good 8% grade ability. With the tiller head being in vertical or horizontal position, an electromagnetic brake will hold the truck.



- With easy read LED battery display and emergency switch can cut-off all electricity.



- Foldable platform is provided with the APT walkie trucks. accelerating vehicle speed when the driver is on the platform. Platform folds automatically once the driver has stepped off, and the speed will reduce automatically with a slow drive speed switch under the platform.



- Polyoxymethylene tiller head provides a 185 degree steer angle. A red safety button will ensure the truck drives forward for improved safety-industrial machinery directive.



- With AC Vectorial Stepless MOSFET inverter effectively provides more progressive acceleration, stable operation and consumes less electricity.



- Foldable side protection guards (Optional)



- Special tools for changing wheels (optional)

## Electric Stackers

### Unmanned & automatic guide system of material handling

Unmanned-  
New Experience



TAIWAN  
EXCELLENCE  
2016

- **Electric Stackers can move between the warehouse area and production area through the automatic guide system without driver.**

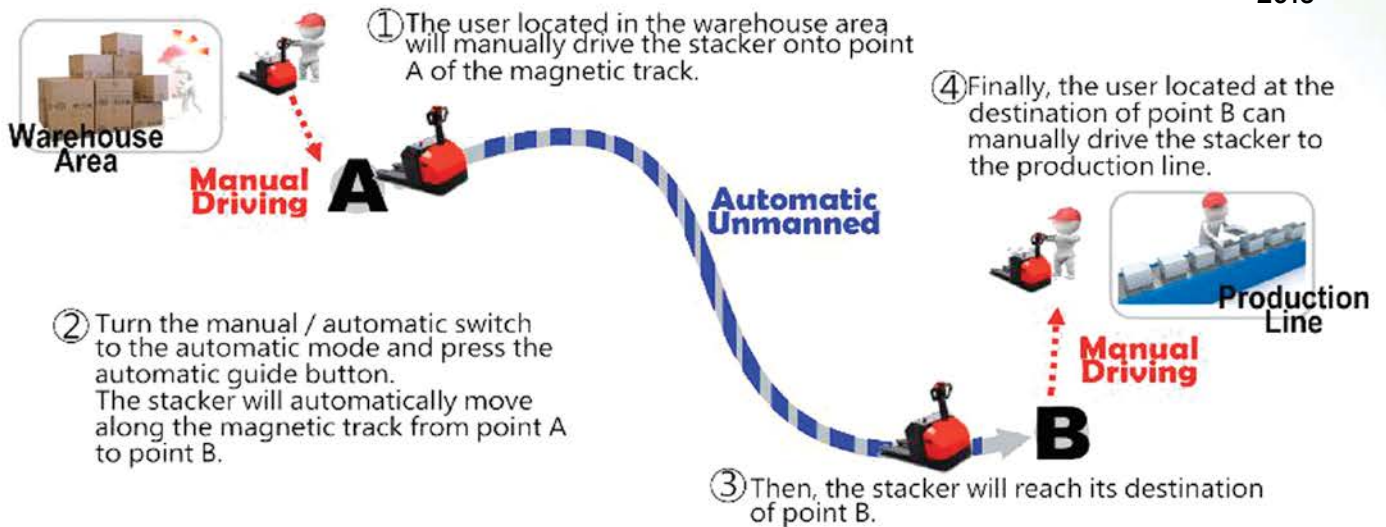

### ● Features of the magnetic sensing guide system

1. Simple to build: the stacker goes automatically wherever the magnetic track has been stuck and installed.
2. Easily adapted for different working environments: the stacker can be set to the mode of the automatic guide operation anywhere the magnetic track has been stuck and installed.
3. Low maintenance cost: with a simple investment at about 1/5 price of the traditional laser guide system, the principal capital invested will be recovered in one year.
4. Unaffected even when the working environment changes.
5. Adapted to install and run in all models of material handling equipment.
6. Load capacity / Grade ability / Lifting capacity are same as those of a normal electric stacker.
7. Convenient to operate with a simple flick of the manual / automatic switch.
8. At a distance of 80 cm from a dangerous situation, the vehicle will slow down automatically; whereas at a distance of 10cm from a dangerous situation, the vehicle will restart to operate only after the obstacle has been removed.

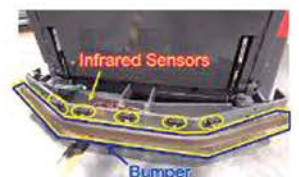

### Mode of automatic driving

**With a simple flick of the manual / automatic switch, the stacker will automatically move along the magnetic to the appointed location.**

**Adapted to install and run in Noveltek's models of ART+EPS, ACS+EPS, APT+EPS and ATT+EPS.**

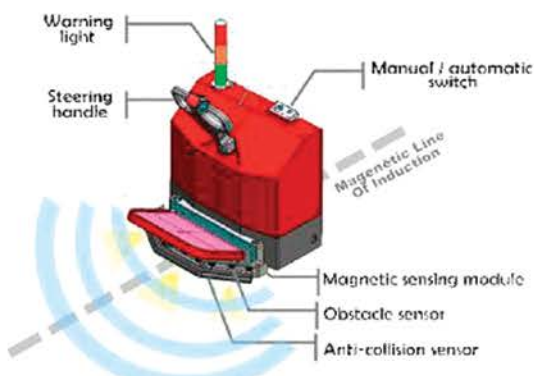

## APT-20/30+EPS Electronic Power Steering

### There are many functions on LED MDI-CAN multifunctional indicator(built-in)

- Indication of battery state of charge
- Operating hour meter
- With CANBUS system, low battery protection alarm shows all trouble coding for easier service use.
- EPS Steering Arm(Electronic Power Steering)  
Steering Arm can work at 185 degree total arc for extra convenience.
- With AC driving motor, it can save electricity efficiently by 30% at least, and carbon brushless equipped for easier maintenance.
- While steering, speed lowering down automatically by 50%.
- Latest AC inverter circuit control system brings stability, power saving, calmness and cleanliness.
- Adjustable speed setting.
- With bright colored coating composed of a defined surface treatment, anti-rust primer and lead-free PU baked enamel painting.
- Professional long-term traction battery for lift-truck use only.
- Customization for clients' requirements.

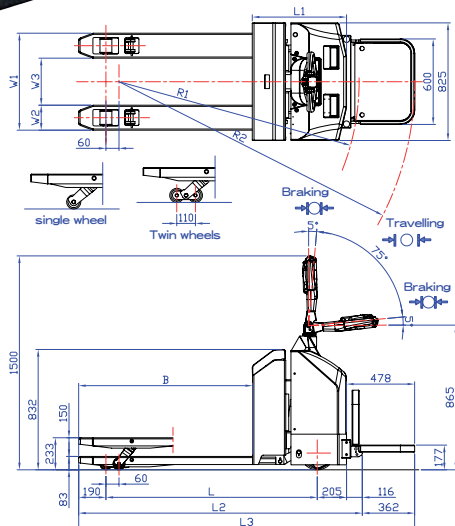

Item	APT-20	APT-30
Rated capacity	2000 KG	3000 KG
Load center	600 mm	600 mm
Lifting speed	empty	2.5 sec
	loaded	3.0 sec
Lowering speed	empty	4.0 sec
	loaded	2.3 sec
Travel speed	empty	6.0 km/h
	loaded	5.5km/h
Grade ability	empty	18%
	loaded	8 %
Weight	w/o battery	1000 KG
	with battery	1215 KG
Fork wheels	Ø83x107 mm x2 (PU)	Ø83x75mm x4 (Twin-wheel)
Drive wheel	Ø235x120 mm x1 (standard: PU ; option: rubber)	
Castor Wheel	Ø102x63 mm x2 (solid)	
Battery	180AH/24V	240AH/24V
Charger	30A/24V (Single Phase)	40A/24V (Single Phase)
Drive motor power	1.6 KW AC	1.6 KW AC
Lift motor power	2.5 KW	
Controller Driving Lifting	AC Stepless Contactor	
Steering motor power	400W	
Inverter	AC Stepless	
Parking brake	Electromagnetic spring pressure	

Item		APT-20	APT-30
Overall fork	W1	680 mm	680 mm
Each fork width	W2	175 mm	175 mm
Fork inner width	W3	330 mm	330 mm
Fork length	B	1150 mm	1150 mm
Max. fork height		233mm	233 mm
Min. fork height		83 mm	83 mm
Overall height		1500 mm	1500 mm
Overall width		825 mm	825 mm
Overall length	L1	657 mm	724mm
Wheel base	L	1412 mm	1487 mm
Overall length sub step is folded	L2	1923 mm	1993 mm
Overall length sub step is open	L3	2285 mm	2355 mm
Min. turning radius	R1	1697 mm	1767 mm
Turning radius	R2	2044 mm	2115 mm
Pedal Length		478mm	478mm

## APT-50/70 AC+EPS ADVANCED POWERED PALLET TRUCK (AC SYSTEM)(5.0 TONS)(HEAVY DUTY)



- LED MDI-CAN multifunctional indicator has many internal functions:
  - Indication of battery's state of charge.
  - Operating hour meter.
  - With CANBUS system, low battery protection alarm and shows all trouble coding for easy service use.
- EPS Steering Arm. (Electronic Power Steering) Steering Arm can work in 185 degree total arc for extra convenience.
- With AC drive motor can save electricity efficiently by 30% and carbon brushless, easy maintenance.
- Powerful Traction Battery
- With bright colored coating composed of a detailed surface treatment, anti-rust primer, and lead-free PU baked enamel painting.

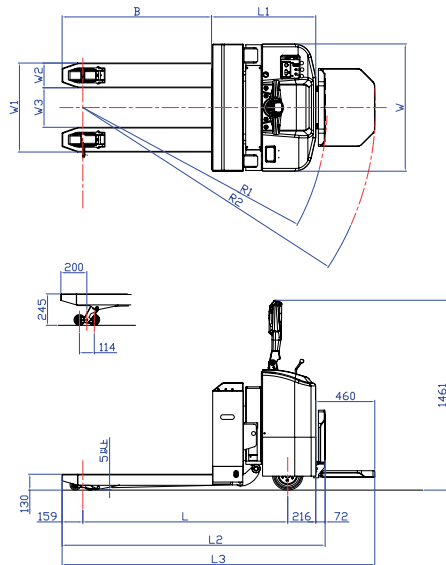

Item		APT-50	APT-70
Rated capacity		5000 KG	7000 KG
Load center		600 mm	600 mm
Lifting speed	empty	7.0 sec	7.0 sec
	loaded	5.0 sec	5.0 sec
Lowering speed	empty	9.0 sec	9.0 sec
	loaded	5.0 sec	5.0 sec
Travel speed	empty	5.5 km/h	6.0 km/h
	loaded	4.5 km/h	4.0 km/h
Grade ability	empty	17 %	18 %
	loaded	6 %	7 %
Weight	w/o battery	1000 KG	1570 KG
	with battery	1215 KG	2000 KG
Fork wheels		Ø83x75 mm x2 (PU)	Ø140x60 mm x2 (PU)
Drive wheel		Ø235x120 mm x1 (standard: PU ; option: rubber)	
Castor Wheel		Ø102x63 mm x2	
Battery		240AH/24V	240AH/48V
Charger		40A/24V (Single Phase)	40A/48V (3 Phase)
Drive motor power		1.6 KW AC	4.0 KW
Lift motor power		2.5 KW	
Steering motor power		400W	
Inverter		AC Stepless	
Parking brake		Electromagnetic spring pressure	

Item		APT-50	APT-70 (Customized)
Overall fork	W1	685 mm	1082 mm
Each fork width	W2	190 mm	350 mm
Fork inner width	W3	305 mm	382 mm
Fork length		1150 mm	1700 mm
Max. fork height		245 mm	260 mm
Min. fork height		130 mm	150 mm
Overall height		1461 mm	1532 mm
Overall width	W	980 mm	1100 mm
Overall length (w/o sub step)	L1	794 mm	1034 mm
Wheel Base	L	1569 mm	1978 mm
Overall length sub step is closea	L2	2016 mm	2806 mm
Overall length sub step is open	L3	2404 mm	3194 mm
Min. turning radius	R1	1881 mm	2233 mm
Turning radius	R2	2254 mm	2583 mm
Pedal Length		460mm	460mm

Option items:

Fork length: 2600mm / fork width: 1000mm

back buzzer, beacon light, stainless steel truck body, -35°C cold storage type...etc.

# NOVELTEK

## PPT-20V/25V/30V Full-Electric Pallet Truck



**TAIWAN  
REWARDED 2012 INDUSTRIAL  
AESTHETICS VIRTUOSO.**

- Especially designed in accordance with idea of aesthetic expertise, it works both functional and aesthetical performances perfectly.
- Strong-shaped appearance with extra loading spaces and file holders
- Stable, mighty driving and lifting motors.
- Unique pump-oil circulator with overloading protection system.
- Hi-tech electric control system with the optional AC or DC one.
- Cold version for -35°C cold storage application.
- Customized model for particular application.



Special Shock-proof Suspension system for best Stability and balance while driving and controlling.



Nitrogen-cylinder foldable pedal



- Reversing safety switch
- Emergency Stop
- File folder
- Aesthetic Dashboard
- Extra placing space



Micro-processor recharger

## PPT-20V/25V/30V Specifications

Item	PPT-20V	PPT-25V	PPT-30V
<b>lifting</b>			
Rated Capacity(kg)	2000	2500	3000
Load Center(mm)	600		
Max lifting Speed(sec)	empty	1.8	2.1
	loaded	3.0	3.5
Max lowering speed(sec)	empty	5.0	
	loaded	1.4	1.5
<b>Driving</b>			
Travel Speed (km/h)	empty	6.0	
	loaded	6.0	5.5
Gradeability (%)	empty	18	
	loaded	8	7
<b>Weight of truck</b>			
Service weight	W/o Battery	480kg	490kg
<b>Wheels</b>			
Fork wheels	Size	Ø85×75mm(Standard)	
	Quantity	2/2	
	Materials	PU	
Castor wheels	Size	Ø140×60mm(Standard)	
	Quantity	1/1	
	Materials	PU	
Drive Wheels	Size	Ø212×75mm	
	Material	Rubber	
	Materials	PU(Optional)	
<b>Battery and motor</b>			
Battery capacity at 5-hour discharging	180AH/24V	240AH/24V	
	Other options available		
Max charging current	30A/24V	40A/24V	
Driving motor AC/DC 24V	1.8kw/1.5kw		
Lifting motor	2.5kw/24V		
Speed control	Stepless AC or DC(Speed adjustable)		
<b>Steering and Brake</b>			
Steering system	Steering Arm		
Steering arch total	185"		
Travel brake	Model	Electromagnetic Spring	
	Actuated part	Driving wheel	
Park brake	Model	Electromagnetic Spring	
	Actuated part	Driving wheel	

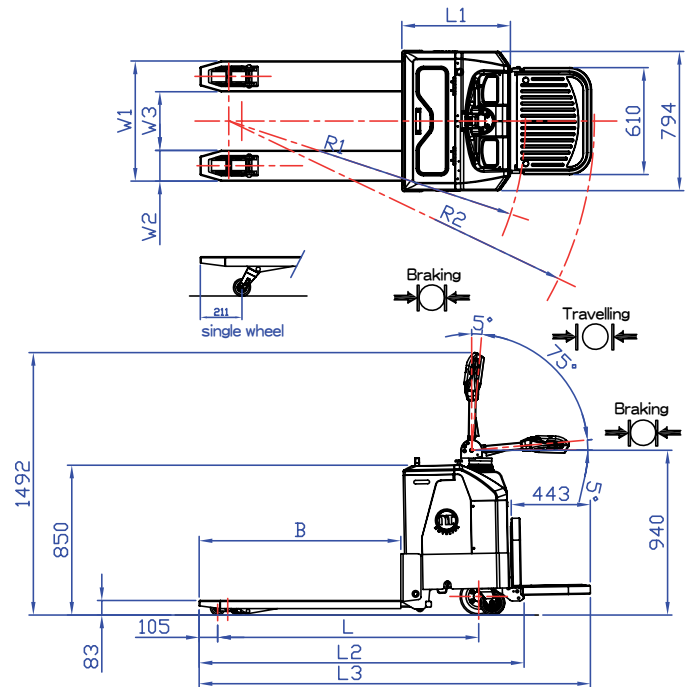

PPT-V Model	20	25	30
Item	mm		
Overall fork width	W1	685	
Fork width	W2	175	190
Fork inner width	W3	335	305
Fork length	B	1150	
Max. fork height	200		
Min. fork height	83		
Overall height	1916		
Overall width	805		
Length of body	L1	677	752
Length of car(w/o pedal)	L2	1911	1919
Length of car(w/ pedal)	L3	2270	2345
Turning radius	R1	1777	1785
	R2	2124	2132
Distance of fork wheels	L	1430	1438



Original European Battery Duration for at least 5-year Dischargeable at least 1500 times High capacity; 8-hour operation after 8-hour recharge



DC Motor: Power saving without carbon brush; economical maintenance



AC Motor: High Power and torque

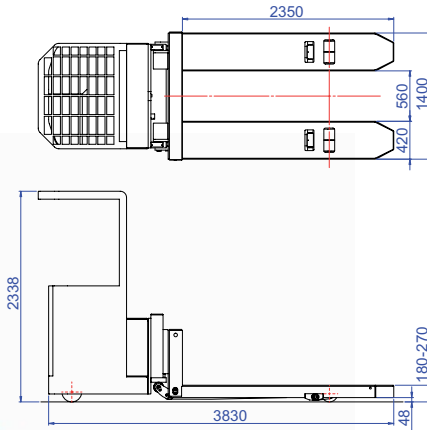
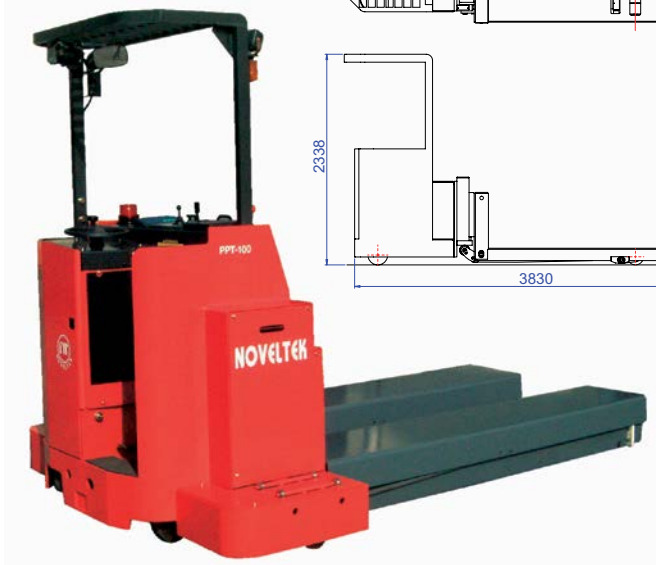

## PPT-80/100/150 POWERED PALLET TRUCK (8.0 TONS / 10.0 TONS / 15.0 TONS)

Item	PPT-80	PPT-100	PPT-150
Rated Capacity	8,000 KG	10,000 KG	15,000 KG
Fork Lifting Height	180~270 mm	285~385 mm	
Overall Length	3830 mm		
Overall Height	2338 mm		
Fork ( L×W)	2350 × 1400 mm (As required)		
Speed Control	Stepless		
Brake	Mechanism		
Drive Wheel *	Ø300×150 mm (Rubber)		
Fork Wheel *	Ø204×76 mm × 6 Pcs (PU)		
Castor Wheel *	Ø127×80 mm × 2 Pcs (PU) (1/1)		
Battery	400 AH/48V	480 AH/ 48V	
Charger	220V /80A ( 3 Phase)		
Service Weight	3500 KG	3800KG	4000 KG
Remark	Fork can be customized to platform as required.		

## PPT-18/20/25/30/40 POWERED PALLET TRUCK (1.8 TONS / 2 TONS / 2.5 TONS / 3 TONS / 4 TONS)

- Ride-on drive, easy handling.
- Quiet, safety, durable, reliable.
- No pollution.
- Electric drive, electric lifting.
- Lead-free PU baked enamel painting.
- When lifting, forks raise alone without battery, thus, the power is economically saved.
- Forks can lift up to 205mm. It can carry open pallet or closed pallet.
- 2 pcs of the hydraulic lifting cylinders are built in right and left sides. It lifts very stable and much better than the single hydraulic lifting cylinder product.
- 2 pcs of the strong castor wheels are fixed at right and left sides. This truck doesn't have any balance problems when turn a circle.
- Suspension drive motor and wheel can move up and down by 45mm. This truck has a very powerful climbing ability. This mechanism is controlled by 3 springs.
- Emergency handle can cut-off all electricity.
- This truck has cold version for -35°C cold storage use.
- Leadless painting

\* Reference dimension only; size is changeable according different model







## ★ PPT-18/20/25/30/40 Specifications ★

Item	PPT-18	PPT-20/25	PPT-30	PPT-40	
<b>★ Lifting</b>					
Rated capacity	1800 kg	2000/2500 kg	3000 kg	4000 kg	
Load center	600 mm	600 mm	600 mm	600 mm	
Max.lifting speed	empty	1.8 sec	1.8 sec	2.0 sec	2.0 sec
	loaded	3.0 sec	3.0 sec	3.5 sec	3.5 sec
Max.lowering speed	empty	5.5 sec	5.5 sec	5.5 sec	5.5 sec
	loaded	3.0 sec	1.4 sec	1.8 sec	1.8 sec
<b>★ Driving</b>					
Travel speed	empty	7.0 km/h	7.0 km/h	6.0 km/h	6.0 km/h
	loaded	5.0 km/h	5.0 km/h	4.5 km/h	4.5 km/h
Gradeability	empty	16 %	15 %	14 %	14 %
	loaded	8 %	8 %	7 %	6 %
<b>★ Weight of truck</b>					
Service weight	with battery	404 kg	688 kg	755 kg	800 kg
	without battery	380 kg	542 kg	265 kg	612 kg
<b>★ Wheels</b>					
Fork wheels	dimension	ø83x90 mm	ø83x75 mm	ø83x75 mm	ø83x75 mm
	quantity(R/L)	1/1	2/2	2/2	2/2
	material	PU			
Castor wheels	dimension	ø140x60mm	ø140x60mm	ø140x60mm	ø140x60mm
	quantity(R/L)	1/1	1/1	1/1	1/1
	material	PU			
Drive wheel S:Rubber O:PU	dimension	ø212x70mm	ø212x70mm	ø212x70mm	ø212x70mm
	material	rubber	rubber	rubber	rubber
	movement up	15 mm	15 mm	15 mm	15 mm
	movement down	30 mm	30 mm	30 mm	30 mm
<b>★ Battery and motors</b>					
Battery capacity at 5 hours discharge rate	100AH/12Vx2	180AH/24V	240AH/24V	240AH/24V	
	Other options are available				
Max. charging current	20A/24V	30A/24V	40A/24V	40A/24V	
DC Drive motor power	1.0 kw/24V	1.5 kw/24V	1.5 kw/24V	1.8 kw/24V	
Lift motor power	2.0 kw/24V	2.0 kw/24V	2.0 kw/24V	2.0 kw/24V	
Speed control principle-number of steps (3-speed is standard, Electronic Mosfet Stepless is optional.)	Resistance-3	Stepless	Stepless	Stepless	
	Stepless (Optional)	Stepless (Optional)	Stepless (Optional)	Stepless (Optional)	
<b>★ Steering &amp; Brake</b>					
Steering system	Steering arm				
Steering arc. total	185 degree				
Travelling brake	type	Electromagnetic spring			
	actuated part	Drive wheel			
Parking brake	type	Electromagnetic spring			
	actuated part	Drive wheel			

1500 Watt Drive Motor provides ample load carrying capacity. Even when fully loaded, the gradient ability still reaches 9%. And special brake system is installed. When Steering Arm is vertical or horizontal, the microsensor is off and the spring electromagnetic pressure works to brake the truck.

Optional items:

Foldable side Protection guards, Longer steering handle, Stopper for ride-on platform, Removable back rest, -35°C cold storage type, 65mm low profile fork height, and 75mm middle profile fork height, Non-marking white rubber drive wheel, Polyurethane drive wheel, High speed drive motor up to 9.0 km/h...etc.

- The bright colored coating is composed of a detailed surface treatment, anti-rusting primer, and baked enamel finish. This superior painting process withstands harsh working environments and assures a much longer life.
- All electrically powered driving and lifting not only save human energy and time, but also keep working environments quiet and clean.
- Firmly-welded steel frame is constructed to preserve structural integrity even upon sustaining super weight. Riding on the handy platform avoids haste in catching up with the truck and reduces physical fatigue.



Castor Wheel under each side of the truck increases balance and prevents turnover as well.

# NOVELTEK

Steering Arm can work in 185 degree total arc for extra convenience. Easy-reach buttons for lifting and lowering and the horn are placed in the middle of the Steering Arm. For safety sake, the red colour safety device on top of steering handle, once the operator touches it, the truck will drive to forward direction. Those operator-oriented designs are what this PPT different from other competitive trucks.

2/2 tandem fork wheels(83mm/3.27") fitted on forks carry more load without damage.

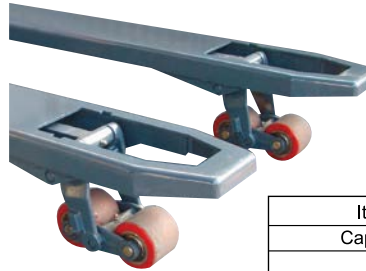
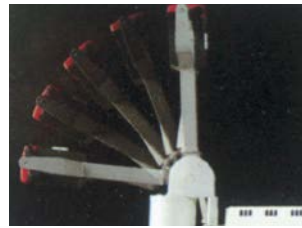

## OPTIONAL SPECIFICATIONS:

W1: Overall fork width 470mm/18.50" 520mm/20.47" 685mm/27"  
 W2: Fork inner width 120mm/4.72" 170mm/6.69" 335mm/13.19"  
 L : Fork length 1000mm/39.37" 1300mm/51.18" 1450mm/57.09"

Items	Unit	PPT-20L	PPT-20S	
Capacity		kg	2000	2000
Travel	Laden	km/h	5.0	5
	Unladen	km/h	6.0	7
Lift Speed	Laden	sec	3.5	3.5
	Unladen	sec	2.5	2.5
Motors	Traction	kw	1.5	1.0
	Hydraulic	kw	2.0	2.0
Control System	Traction		Stepless	Resist-3
	Hydraulic		Contactor	Contactor

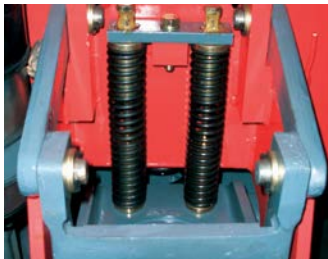

Interior-mounted Cushion Absorbers lessen wobbling and prove extra steadiness.

When loaded, specially designed hydraulic-mechanical system evens the weight to castor wheels and drive wheel, making Steering Arm light to control, yet enough to turn and climb.

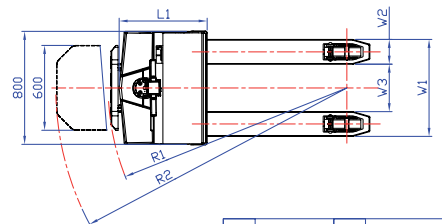

Resistance-3 controller

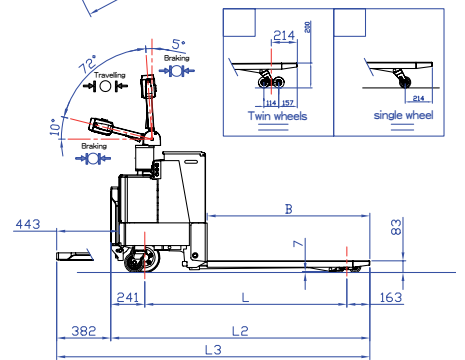

Stepless MOSFET Controller (Optional)

Model(PPT) Tons	18	20/25	30	40
Item	mm	mm	mm	mm
Overall fork width (W1)	580	580	580	580
Each fork width	175	175	190	190
Fork inner width (W2)	230	230	200	200
Fork length (L)	1150	1150	1150	1150
Max. fork height	200	200	200	200
Min. fork height	83	83	83	83
Front end length	170	60	60	60
Overall height	1400	1400	1400	1400
Overall width	800	800	800	800
Turning radius (R2)	1585	1660	1667	1679
(R1)	-	2057	2064	2076
Length of Body (L2)	1429	1429	1435	1447
W heel Base (L)	1833	1833	1840	1852
Body length (w/pedal) (L3)	2215	2215	2222	2233
Distance of fork wheels	85	200	200	200



Traction Battery used in the truck endures about 5 years and can be operated normally for 8 hours after 8 hours charge. 2 pcs of the hydraulic lifting cylinders lift forks and goods only. They are very stable at both sides.

When lifting, forks raise alone without battery lifting together; thus, the power is economically saved.

## POPS-10

### POWERED ORDER PICKER STACKER (1000 KGS, 2200 LB)

- The order picker can stand in-side of the lift table and control up/down.
- Adjustable forged forks, suitable for any kinds of pallets.
- Raise the forks a further 800mm for picker use. The max fork lifting height is the max lift table height plus 800mm.
- Ride-on platform at back-side for driving use.
- Double hydraulic control systems in the lift table and ride-on platform.
- Lead-free PU baked enamel painting.

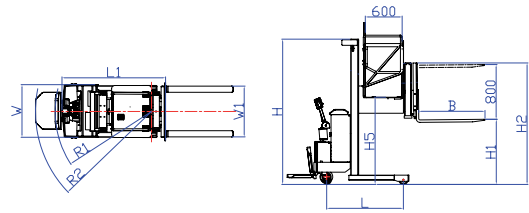

Description		POPS-10								
Rated Lifting capacity		1000 kg								
Load center		500 mm								
Max. Lifting speed	Empty	210 mm								
	Loaded	130 mm/s								
Max. Lowering speed	Empty	290 mm/s								
	Loaded	500 mm/s								
Travel speed	Empty	4 km/h								
	Loaded	3 km/h								
Gradeability	Empty	8%								
	Loaded	5%								
Battery capacity at 5 hours discharge rate (Traction Battery)		240A/24V								
Charger:(220Vx1ø)(With microprocessor) (Optional:110Vx1ø)		40A/24V								
Drive Wheel		Ø212X70 mm								
Drive motor power		1.5 KW/24V								
Main lift motor power		3.0 KW/24V								
Small lift motor power		2.0 KW/24V								
Speed control principle number of steps		Stepless								
Body Length		L1	1600 mm							
Body Width (w/o fork)		W	850 mm							
Outer width of forks		W1	850 mm							
Wheel base		L	1250 mm							
Fork length		B	1070 mm							
Turning radius		R1	1460 mm							
Turning radius		R2	1900 mm							
Service Weight	With battery	1715 kg								
	Without battery	1500 kg								
Picker fork lift Height		800mm								
Front wheel		Dimension	ø150x50 mm							
		Quantity(R/L)	1/1							
		Material	PU							
Main mast type		Duplex mast telescopic								
Standard fork max. height (mm)		H1	2000	2500	3000	3500	4000	4500	5000	5500
Min. mast height (N) (mm)		H	1600	1850	2100	2350	2600	2850	3100	3350
Max. mast height (P) (mm)		H2	3300	3800	4300	4800	5300	5800	6300	6800
Picker working height (mm)			4000	4500	5000	5500	6000	6500	7000	7500
Max. Fork lifting height (mm)		H1+800mm	2800	3300	3800	4300	4800	5300	5800	6300

## SPOP-02

### SEMI-POWERED ORDER PICKER STACKER (200KG, 440LB)

- Quiet, clean, high quality.
- The picker can pick the goods at 4.5 Meter high.
- Picking height 5.0 And 5.5 Meter are optional.
- Charger of 110V/12V-12A (build-in) is optional.
- Manually propelled, powered lifting order picker stacker.
- The up/down switch is built in the side rail. It is very easy to handle.
- Light weight stacker. It is very easy operated and very durable quality.
- 2 pieces of foot parking brakes.
- -20°C cold storage type is optional.

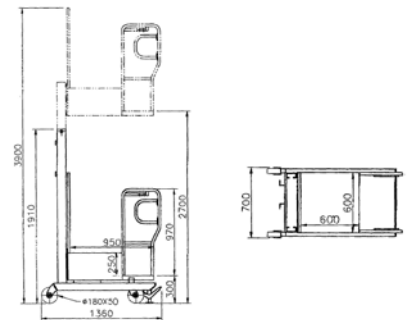

Model:		SPOP-02	
Load capacity		200 kg	
Service weight		308 kg	
Overall length		1360 mm	
Overall width		700 mm	
Min. mast height		1910 mm	
Max. height		3900 mm	
Max. lifting height		2700 mm	
Min. stand height		550 mm	
Loading stand height		250 mm	
Platform overall length		970 mm	
Loading stand length		600 mm	
Loading stand width		600 mm	
Rear wheel		ø180x50 mm	
Front wheel		ø180x50 mm	
Hand rail height		970 mm	
Lifting speed		10-14 M/MIN	
Lowering speed		6-9M/MIN	
Lifting motor		1.5 KW/12V	
Battery		135AH/12V	
Charger(220v/110v)(1Phase)		12V-12A	



Anti-fall down device, Emergency descend device & Brake safety device are options.

## ABT-160

### AC ELECTRIC TOW TRUCK(4 WHEELS) (AC SYSTEM) (8 TONS / 16 TONS)

- High quality AC drive motor.
- Power steering on front wheels.
- Power drive on rear wheels.
- Very easy operate.
- Very strong towing force, it can tow 16 tons' trolley on normal floor, it can tow 8 tons' trolley over ramp.
- Tow hook at rear.
- AC stepless electric inverter.
- Microprocessed charger with equalizing function.
- Hydraulic foot brake.
- Mechanical hand parking brake.
- Stable hydraulic power steering.
- Adjustable and cushion seat with seat belt and a safety switch in this seat.
- Lead-free PU baked enamel painting.

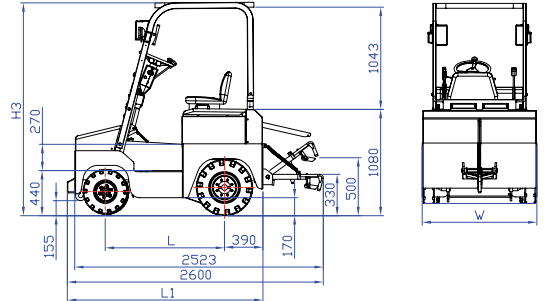
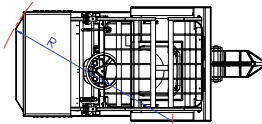

Towing capacity		16000 KG (At flat floor) 8000 KG ( with 8% gradeability)
Travel speed	Loaded	8 km/h
	Empty	13 km/h
Gradeability	Loaded	8 %
	Empty	24 %
Truck weight	With Battery	2000 KG
Wheel base	L	1220 mm
Overall length	L1	1990 mm (w/o towbar)
Overall height	H3	2170 mm
Overall width	W	1170 mm
Tow bar height		500 mm ( or customized)
Turning radius	R	1860 mm
Drive tires ( Rear)		6.5-10
Steering tires (Front)		5.00-8
Battery (5 HRS)		400 AH/48V
Charger		220V/48V-80A
AC Drive motor (48V)		8 KW
Power steering motor		0.8KW
Brake		Electromagnetic spring pressure
Hook		Pin type ( or customized)
Standard Equipment		Head Light, Back Light, Signal Light, Rear Mirror, Back Buzzer, Horn

## ATT-60SW

### ADVANCE TOW TRUCK (STEERING WHEEL) (AC SYSTEM) (6 TONS)

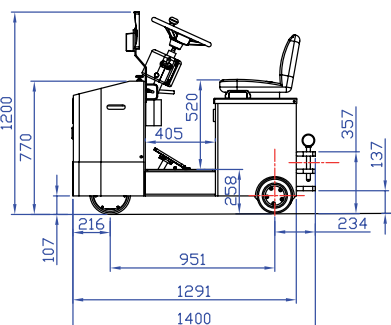
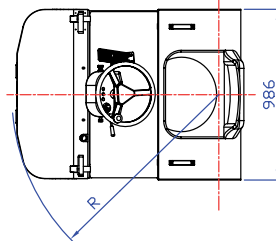

Item	ATT-60	
Towing	6000 kg (at flat floor)	
	3000 kg (with 8% gradeability)	
Travel speed	loaded	3.2 km/h
	empty	8.1 km/h
Grade ability	loaded	9 %
	empty	17 %
Truck weight	w/o battery	700 kg
	with battery	915 kg
Loading wheels	Ø212x70 mm (PU)	
Drive wheel	Ø235x120 mm (rubber) Solid	
Battery(5hrs)	240AH/24V	
Charger	220V/24V-40A	
Drive motor	2.0 kw/24V (AC)	
Controller	AC stepless	
Brake	Electromagnetic spring pressure brake	
Hook	Pin type (or customized)	
Standard equipment	Head light, rear mirror, back buzzer, horn	

## ATT-50 + EPS

### ADVANCED TOW TRUCK (AC SYSTEM) (5 TONS, 11000LB) Electronic Power Steering system (EPS system) very easy to drive

- Electronic Power Steering system (EPS system) very easy to drive
- Advanced AC motor product (AC drive motor 1.6Kw/24V)
- Without carbon brush, reduce service cost
- Save electricity efficiently by 30%
- FRP body cover and battery cover
- Lead-free PU baked enamel painting
- Polyoxymethylene Steering Arm
- No pollution, quiet, safety, durable and reliable
- Tow capacity is powerful and could pull 5 tons (11000lb) lorry on normal flat floor
- It can tow 3 tons lorry over ramp
- Seat is an optional item

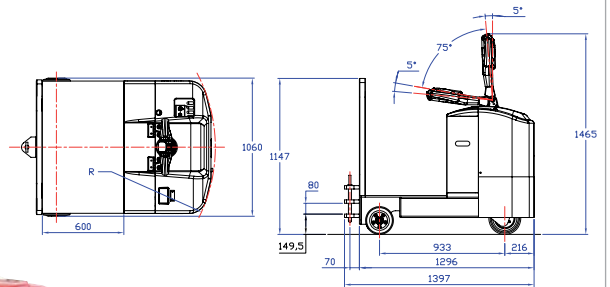

#### ATT-50

Towing capacity	5000kg (at flat floor)	
Travel speed	loaded	3.0 km/h
	empty	6.0 km/h
Gradeability	loaded	9%
	empty	17%
Weight of truck (240AH)	with battery	965 kg
	w/o battery	750 kg
Load wheels	PU	ø212x70 mm
Drive wheel	PU	ø235x120 mm
Battery capacity at 5 hours charge(24V)	240 AH	
Max. Battery charger current(24V)	40 A	
Inverter	AC stepless	
Steering Arc. total	185 degree	
Traveling brake	type	Electromagnetic spring pressure
	actuated	Drive wheel
Parking brake	type	Electromagnetic spring pressure
	actuated	Drive wheel
	hook	Pintype

Customer's special requirement dimensions are welcome to produce.Hour meter, pad, seat, beacon light and back buzzer, special towing hook...etc. are optional.

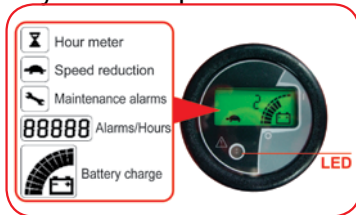

LED MDI-CAN multifunctional indicator



Power unit

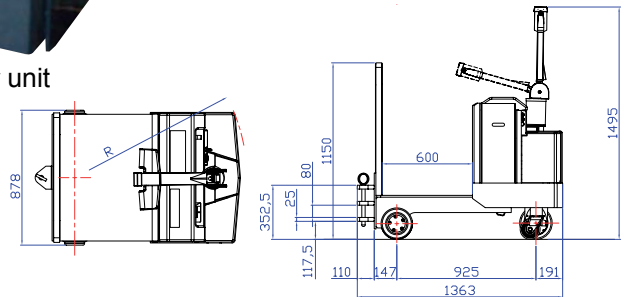

## TT-50

### TOW TRUCK(5 TONS, 11000LB)

- The driver operates in the center of truck.
- Safety and convenience.
- Turning radius is very small. The operation is convenient.
- Tow capacity is powerful and can drag 5 tons(11000 lb.) lorry on normal flat floor.
- It can tow 3 tons lorry over ramp.
- Seat is an optional item.
- Lead-free PU baked enamel painting



Towing Capacity	5000 kg(at flat floor)	
	3000 kg(with 10% gradeability)	
Max. Travel Speed	empty	6.0 km/h
	loaded	3.0 km/h
Truck Weight	688 kg(with battery)	
Battery	240AH/24V(traction) other options are available	
Drive Wheel(Front)	ø212x70 mm(solid tyre)	
Load Wheels(Rear)	ø205x70 mmx2pcs(solid pu tyres)	
Drive Motor	1.5kw/24v	
Charger	220V/40A(microprocess)	
Steering	steering arm 185 ARC	
Electric Control	Electronic mosfet stepless is optional 3 speed is standard.	
Electric Cut off	emergency cut-off handle. microprocess charger cut-off.	
Seat	Stand-on is standard. Seat is option.	
Brake	electromagnetic spring pressure	
Instrument	horn, battery discharge indicator.	
Hook	Pin type	
Main Dimension	1190(L)x850(W)x1460(H)mm	

Customer's special requirement dimensions are welcome to produce.  
Hour meter is optional.

## EPT-15A ELECTRIC PALLET TRUCK

- Light Body, suitable for running in narrow space.
- Standard forks, suitable for most pallets.
- Stepless speed-adjustment system.
- Human dynamics steering arm for convenient and safe control.
- Multiple safety devices for avoiding accident effectively.
- Artificial intelligence electricity protection with low-voltage protection.
- Built-in recharger for convenient charging.

Optional: fork width:685mm/520mm  
Fork length:1150mm/1220mm



Hi-quality Curtis controller.



Strong truck frame with reinforced fork structure.



Robust metal shell protecting electric motor and wheels avoids hurting of foot.



Emergency stop button and voltage gauge conforming to human dynamics.

Model	EPT-15A		
LIFTING			
Load Capacity	1500kg		
Load Center	600mm		
DRIVING			
Traveling speed	Empty	4.4Km/h	
	Loaded	4.2Km/h	
Gradeability	Empty	10 %	
	Loaded	4 %	
BATTERY AND MOTORS			
Battery	80AH/12V×2		
Driving Motor(DC)	0.45kW/24V		
Lifting Motor(DC)	0.80kW/24V		
Speed control	Stepless		
Charger	24V/8A/220V/1 Phase		
STEERING AND BRAKE			
Steering System	Steering Arm		
Steering arc. total	185°		
Brake	Electromagnetic Spring		
Operation Type	Walking		
WHEEL			
Driving Wheel	Size	ø220×70mm	
	Material	PU	
Castor Wheel	Size	ø80×30mm	
	Quantity	1/1(L/R)	
	Material	PU	
Fork Wheel	Size	ø80×70	
	Quantity	1/1	
	Material	PU	

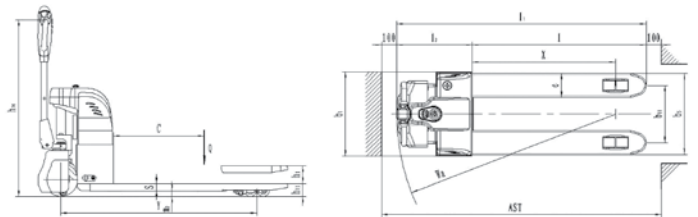

EPT-15A SIZE			
Overall length(with fork)	mm	l1	1660
Overall width	mm	b1	705
Turning Radius	mm	wa	1460
Fork length	mm	l	1150
Load Center	mm		600
Body length	mm	l2	510
Each fork width	mm	e	160
overall fork width	mm		685
Min fork height	mm	h13	80
Max fork height	mm		195
Weight	Kg		190

## HPT-20/25/30

### HAND PALLET TRUCK(2 TONS / 2.5 TONS / 3 TONS)

- Load capacity 2000kg/2500kg/3000kg.
- High quality hydraulic lifting
- Durable and reliable cylinder.
- No oil leakage.
- Easy handling.
- Easy lifting.
- Baked enamel painting.
- With an overload relief valve to avoid misuse due to over loading.
- Steer and fork wheels, made by steel and covered by polyurethane.



There is no special operation training required. The spring-loaded loop handle provides easy operation and automatically returns to vertical position when released. Neutral position allows the operator to handle load at the most convenient angle.

One piece "C"-channel formed steel reinforces fork strength to carry more load without bending. Incorporated with DUCTILE IRON castings at pivotal points, no grease fitting is required. Dual wheels sets are also available. Every 6 units are packed on a wooden pallet for export. An entry roller has fitted at the front of each fork.

· Reliable, durable and critical hydraulic pump withstands thousands of lifting/ lowering cycles. And it is well sealed to prevent leaking.

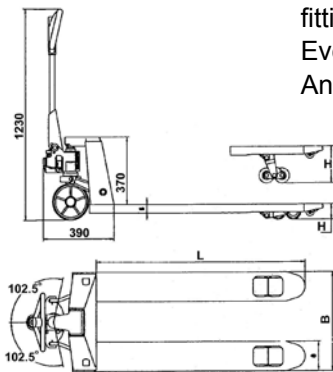

Item	Standard	Option
Fork Height lowered(H1) lifted(H2)	85 mm 200 mm	75 mm 190 mm
Fork Wheels	ø 82 mm x 70 mm	ø 76 mm x 93 mm
No. of Fork Wheels	2 pcs x 2	1 pc x 2
Steer Wheels	ø 180 mm x 50 mm	ø 180 mm x 50 mm
Wheel Material	Steel Covered By Poly-urethane	Steel Covered By Nylon
Service Weight	2 tons: 81 kg / 3 tons: 87 kg	
Fork Thickness	45 mm	

Model	Overall Width(A)	Fork Length(L)	Inner Width(B)
HPT-NS	520 mm	910 mm	200 mm
HPT-NM	520 mm	1070 mm	200 mm
HPT-WM	685 mm	1070 mm	365 mm
HPT-WL	685 mm	1220 mm	365 mm

## HPT-40/50

### HAND PALLET TRUCK (4 TONS / 5 TONS)



<b>HPT-40</b>	Standard
Fork height Lowered Lifted	85mm 205mm
Fork wheels	ø80mm x 60mm (tandem)
No. of fork wheels	2pcs x 2
Steer wheels	ø200mm x 60mm
Wheel material	Steel Covered By Poly-urethane
Each fork width	160mm
Fork thickness	60mm
Size	L900mm x W520mm
	L1050mm x W520mm
	L1220mm x 680mm
<b>HPT-50</b>	Standard
Fork height Lowered	90mm
Fork wheels	ø85mm x 70mm (tandem)
No. of Fork wheels	2pcs x 2
Steer wheels	ø200mm x 70mm
Wheel material	Steel Covered By Poly-urethane
Each fork width	190mm
Size	L1220mm x W700mm or W800mm
	L1500mm x W700mm or W800mm

\* Customer's special requirement dimensions are welcome to produce.

## ELT-02~50 (200KG-5000KG) ELECTRIC LIFT TABLE

Double Scissor



Tandem



Single Scissor



Triple Scissor



Zero-low



Sliding



## DOCK LEVELER

This product is designed for the height adjustment between loading dock and container in favor of the convenience of lift truck to work well inside and outside container, in which the efficiency will be definitely promoted.

Model	Size mm	Capacity kg	Power hp/kw
DL-18A	1830*2424(6'*8')	11,000(25,000lb)	1
DL-19A	1980*2424(6.5'*8')	11,000(25,000lb)	1
DL-21A	2130*2424(7'*8')	11,000(25,000lb)	1
DL-18H	1830*2424(6'*8')	15,000(35,000lb)	1
DL-19H	1980*2424(6.5'*8')	15,000(35,000lb)	1
DL-21H	2130*2424(7'*8')	15,000(35,000lb)	1
DL-21HL	2130*3060(7'*10')	15,000(35,000lb)	1





## BLT-300 / 350D / 500 / 800 BATTERY LIFT TABLE

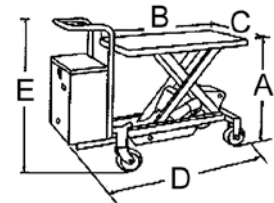
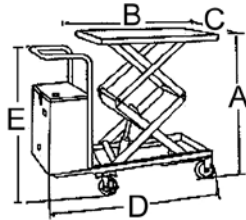

Model		BLT-300	BLT-350D	BLT-500	BLT-800
Load capacity (kg)		300	350	500	800
Max. lifting height (mm)	A	875	1300	960	1000
Min. lifting height (mm)		275	355	295	410
Table length (mm)	B	815	910	910	1000
Table width (mm)	C	500	520	520	513
Overall length (mm)	D	1180	1260	1260	1390
Overall width (mm)		520	540	540	580
Handle height (mm)	E	1015	1015	1015	1035
Wheel size (mm)		Ø127x40mm	Ø127x40mm	Ø127x40mm	Ø150x40mm
No. of brake		1	1	1	2
Service weight (kg)		125	145	135	160
Lifting motor power		1500W	1500W	1500W	1500W
Charger (buid-in)		110 or 220V	110 or 220V	110 or 220V	110 or 220V
Battery (12V)		65AH	65AH	65AH	65AH

Note: D: Double pantograph

\*option item: 8" wheel, moveable handle cable control, wireless remote control, AC motor...etc.

## LT-150F/300F/350D/500/500D/800/1000 LIFT TABLE(150KG-1000KG)

MODEL	LT-150F	LT-300F	LT-350D	LT-500	LT-500D	LT-800	LT-1000
LOAD CAPACITY(KG)	150	300	350	500	500	800	1000
A MAX.LIFTING HEIGHT(MM)	750	890	1300	950	1300	1000	1000
MIN.TABLE HEIGHT(MM)	250	275	335	295	355	410	410
B TABLE LENGTH(MM)	700	810	910	910	910	1000	1000
C TABLE WIDTH(MM)	450	500	520	520	520	513	513
D OVERALL LENGTH(MM)	875	1020	1098	1100	1098	1320	1320
E HANDLE HEIGHT(MM)	825	960	960	960	960	980	980
OVERALL WIDTH(MM)	450	500	520	520	520	575	575
WHEELS SIZE(MM)	100X32	127X38	127X38	127X38	127X38	150X40	150X40
NO. OF BRAKE	1	1	1	1	1	2	2
SERVICE WEIGHT(KG)	34	72	95	85	100	110	115

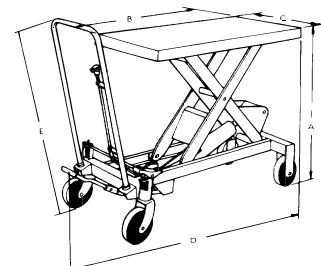

Note. F: foldable handle

D: double pantograph

- 2 Brakes on 2 wheels is standard for LT-800/1000.
- 2 Brakes on 2 wheels is optional for LT-300F~LT-500D.

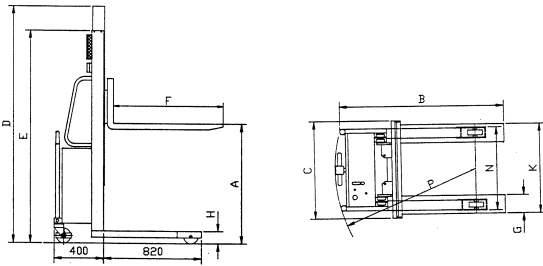

Item	SPS-10	
Mast Type	Telescopic	
Load Capacity	1000 kg	2200 lb
Load Center	450 mm	17.72"
A Max. Fork Height	2500 mm	98.37"
Service Weight	320 kg	740 lb
Battery	135AH/12V other options are available	
Charger(220V / 110V)(1Phase)	12A(BUILD-IN)	
Lifting Motor	1.5KW/12V	
Fork Wheels	Ø80X70 mm	Ø3.15"X2.75" mm
Material	Poly-urethane With Bearing	
Steering and Caster	Ø180X50 mm	Ø7.09"X2.00" mm
Wheel Material	Poly-urethane With Bearing	
B Overall Length	1450 mm	57.09"
C Overall Width	770 mm	30.31"
D Max. Mast Height	3030 mm	119.29"
E Min. Mast Height	1780 mm	70.08"
F Fork Length	900 mm	35.43"
G Each Fork Width	150 mm	5.91"
H Min. Fork Height	95 mm	3.54"
J Fork Thickness	65 mm	2.56"
K Distance of Forks	330-750 mm	13.00"-29.53"
L Straddle length	820 mm	32.28"
M Each Straddle Width	100 mm	3.84"
N Distance of Straddle	690 mm	27.17"
P Turning Radius	1350 mm	53.15"
Q Length of Body	400 mm	15.75"
Straddle Height	80 mm	3.15"

## SPS-10/12/15/10W/12W/15W MANUALLY PROPELLED, POWERED LIFTING PALLET STACKER (1 TON / 1.2 TONS / 1.5 TONS)

- SPS-10, an electric powered hydraulic lifting, manually-propelled and load capacity 1000kg(2200lb); fork length 900mm(35.43"), adjustable width, lifting height 2500mm(98.4") or 3000mm(118") or 3500mm(137.8"), and wide straddle version available too.
- In addition, SPS-10W wide straddle version type is used for closed pallets. It has fork wheel 80mm(3.15") or 180mm(7.09") diameters for your choice and the straddle inner width will be 1240mm,1140mm, etc.
- Charger of 110V/12V-12A (build-in) is optional.
- Distance of straddle outer width has option 530mm for european pallets.
- Load capacity 1200kg (SPS-12 and 1500kg(15W) are optional.

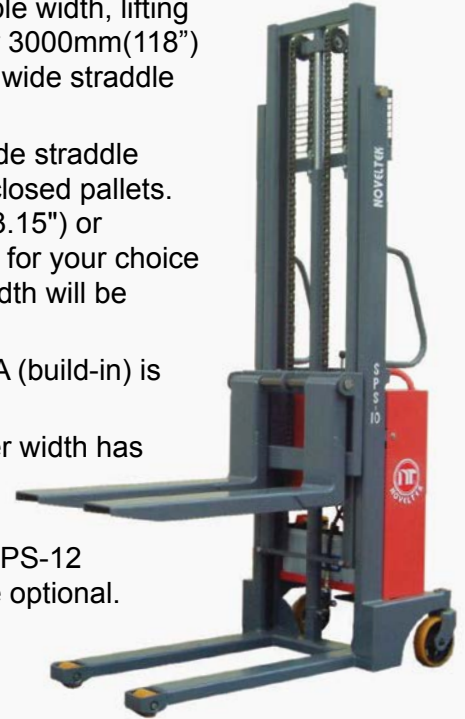

## EPS-10/2500

### ECONOMIC POWERED STACKER (1.0 TON)

- Electric driving, electric lifting. • Easy handling.
- Save time, manpower and cost.

Item	EPS-10/ 2500
Load Capacity	1000 kg
Load Center	450 mm
Battery	135AH /12V
Charging Current ( 220V )	12A ( Build-in)
Lifting Motor	1.5 KW/ 12V
Driving Motor	500W/ 12V
Drive Wheels	Ø160mm x 56mm
Controller	Stepless
Full Load Driving Speed	2.0 km/ H
Empty Driving Speed	2.5 km/ H
Brake	Electromagnetic Brake
Fork Wheels	Ø 80 x 70mm
Material	Poly-urethane with bearing
Steering and Caster Wheel	Ø 180 x 50mm
Fork Lifting Height	90- 2500mm
Overall Length	1610mm
Overall Width	970mm
Mast Height	1780- 3030mm
Fork Size	W150 x L900mm
Outer Width of Forks	330-750mm ( Adjustable )
Straddle Size	100 x 820mm
Straddle Height	80 mm
Outer Width of Straddles	690mm
Turning Radius	1400mm

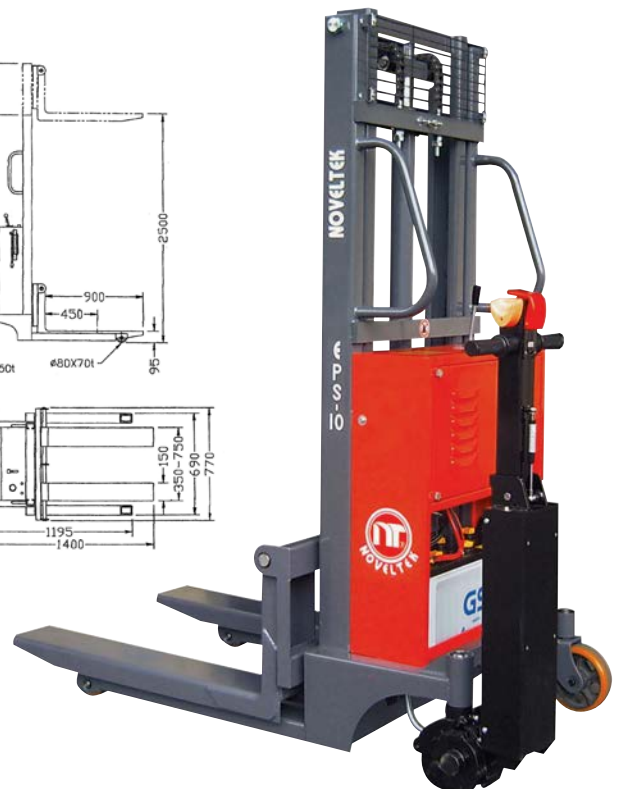
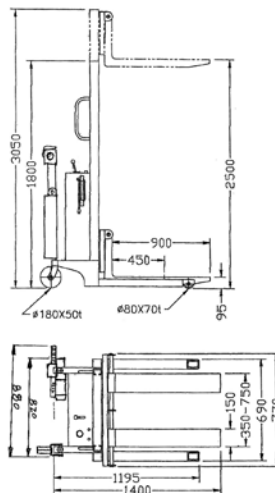

## MPS-04 MANUAL PALLET STACKER(400KG)

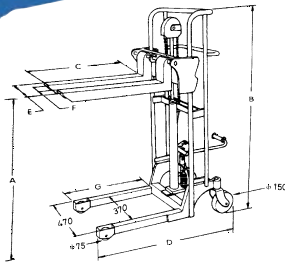

MODEL:MPS-04/	1100	1100A	1500	1500A	1700	1700A	1820	1820A
LOAD CAPACITY(kg)	400	400	400	400	400	400	400	400
A MAX. LIFTING HEIGHT(mm)	1100	1100	1500	1500	1700	1700	1820	1820
FORK WIDTH TYPE	FIXED	ADJUST-ABLE	FIXED	ADJUST-ABLE	FIXED	ADJUST-ABLE	FIXED	ADJUST-ABLE
B OVERALL HEIGHT (mm)	1350	1350	1750	1750	1950	1950	2070	2070
OVERALL WIDTH (mm)	600	600	600	600	600	600	600	600
EACH FORK WIDTH (mm)	110	110	110	110	110	110	110	110
C FORK LENGTH (mm)	610	640	610	640	610	640	610	640
D OVERALL LENGTH (mm)	1050	1160	1050	1160	1050	1160	1050	1160
E MAX. FORK OUTER WIDTH(mm)	550	540	550	540	550	540	550	540
F MAX. FORK INNER WIDTH(mm)	330	315	330	315	330	315	330	315
G STRADDLE LENGTH (mm)	565	675	565	675	565	675	565	675
MIN. FORK HEIGHT (mm)	85	85	85	85	85	85	85	85
FRONT WHEEL (mm)	Ø75X34	Ø75X34	Ø75X34	Ø75X34	Ø75X34	Ø75X34	Ø75X34	Ø75X34
REAR WHEEL (mm)	Ø150X40	Ø150X40	Ø150X40	Ø150X40	Ø150X40	Ø150X40	Ø150X40	Ø150X40
SERVICE WEIGHT (kg)	92	97	108	113	112	117	118	121
PLATFORM(LXW) (mm)	610X570	640X570	610X570	640X570	610X570	640X570	610X570	640X570

Note: A: adjustable fork width

- Manual foot operated lifting hydraulic stacker.
- One wheel with brake is standard.
- Two wheels with two brakes are option.
- Maximum fork lifting height:1100~1820mm.
- Single action pump.
- Light duty stacker.

## MPS-10/12/15/10W/12W/15W MANUAL PALLET STACKER(1 TON/1.2 TONS/1.5 TONS)



- Manually hydraulic pump lifting.
- Easy handing.
- Easy lifting.
- Load capacity:1000kg
- Max. lifting height:1500mm is standard, 1600mm is optional.
- For small area use.
- For not frequent user.
- In addition, (MPS-10W) wide straddle version is used for closed pallets.
- It has fork wheel 80mm (3.15") or 180mm (7.09") diameters is optional for your choice, and the straddle inner width will be 1240mm, or 1140mm...etc. too.
- There 's an option 530 mm (distance of straddle outer width) for European closed pallets.

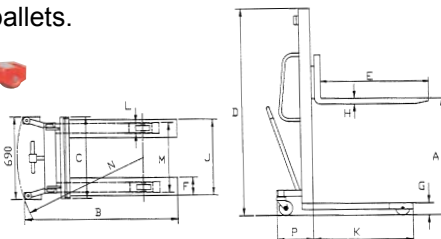

Item	MPS-10/1500(Standard)	
Load Capacity	1000 kg	2200 lb
Load Center	450 mm	17.72"
A Max. Fork Height	1500 mm	59.05"
Service Weight	180 kg	396"
Fork Wheel Material	ø80x70 mm poly-urethane	ø3.15"x2.75" ←
Steering And Caster Wheel Material	ø180x50 mm poly-urethane	ø7.09"x2.00" ←
B Overall Length	1300 mm	51.18"
C Overall Width	710 mm	27.95"
D Overall Height	1880 mm	74.00"
E Fork Length	900 mm	35.43"
F Fork Width	150 mm	5.90"
G Min. Fork Height	85 mm	3.54"
H Fork Thickness	65 mm	2.56"
J Distance of Forks	330-650 mm	13.00"-25.98"
K Straddle length	820 mm	32.28"
L Each Straddle Width	100 mm	3.94"
M Distance of Straddle	590 mm	27.16"
N Turning Radius	1300 mm	51.18"
P Length of Body	330 mm	13.00"
Straddle Height	90 mm	3.35"

- Load capacity 1200kg(MPS-12) and 1500kg(MPS-15) are optional.

## POTR-03/2400

### MANUALLY PROPELLED, POWERED LIFTING STANDARD OIL TANK ROTATING STACKER

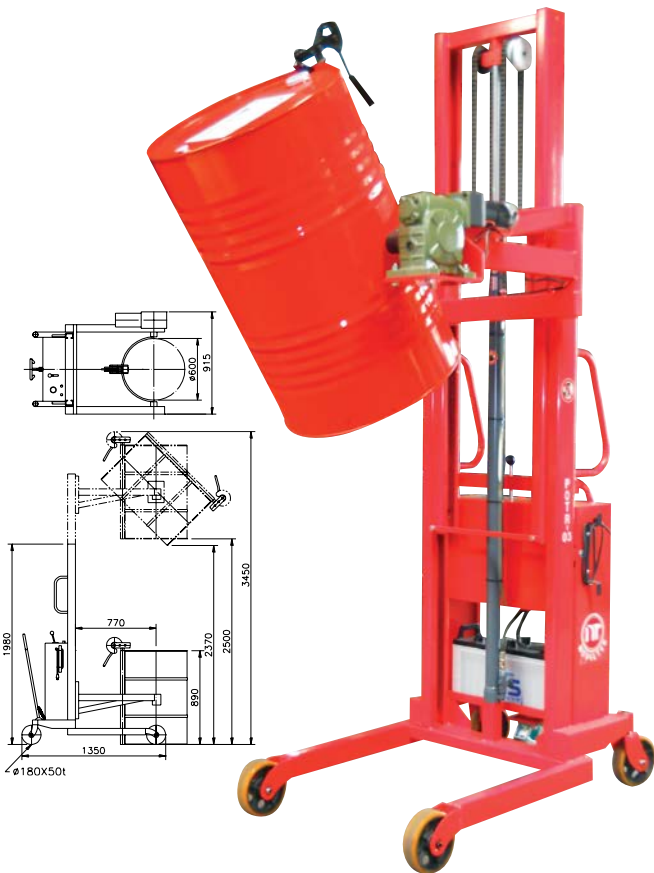

- Min. mast height = 1890 mm
- Overall truck length = 1350 mm
- Overall truck width = 915 mm
- Standard oil tank = Ø580 mm x h890 mm
- Max. oil tank top height = 3450 mm
- Max. oil tank 45°
- Bottom height = 2370mm
- Load center = 770 mm
- Min. clamp center height = 440 mm
- Straddle length = 770 mm
- Electric power operated hydraulic lifting cylinder
- Electric operated rotating gear set of 360°
- Lifting capacity = 300 kg
- Turning radius = 1300 mm
- Front & rear wheels = Ø180x50 mm
- Battery = 135AH/12V
- Charger = 110V/12V-12A or 220V/12V-12A
- Total truck weight = 320 kg
- Clamp method : upper and lower quickly clamp
- The digital weight scale is an optional item.  
It can turn to zero and deduct weight
- Weighing tolerance : 1000 kg±0.1 Kg.

## MOTR-03/1400

### MANUAL STANDARD OIL TANK ROTATING STACKER

- Lifting capacity : 300 kg
- Overall truck length : 1200 mm
- Overall truck width : 940 mm
- Min. mast height : 1980 mm
- Max. lifting height : 1400 mm
- Max. oil tank 45° bottom height : 1370 mm
- Max. oil tank top height : 2350 mm
- Truck weight : 195 kg
- Straddle length : 770 mm
- Min. clamp center height : 440 mm
- Turning radius : 1250 mm
- Front & rear wheels : Ø180x50 mm
- Manual operated hydraulic lifting cylinder
- Manual operated rotating gear set of 360°
- Standard oil tank : Ø580 mm x H890 mm
- Clamp method : upper and lower quickly clamp

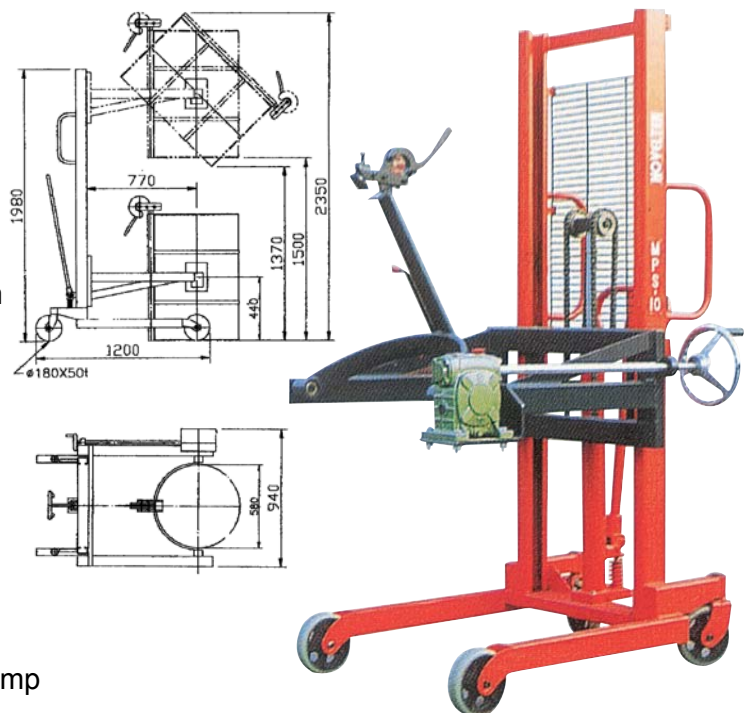

## MOTL-03/500 MANUAL OIL TANK LIFT TRUCK

Manual operated hydraulic lifting cylinder.  
Upper quickly clamp.



Lift Capacity	300 kg
Load Center	300 mm
Min. Mast Height	950 mm
Max. Mast Height	1150 mm
Front & Rear Wheels	Ø180 × 50mm
Truck Length	980 mm
Truck Outer Width	800 mm
Truck Inner Width	650 mm
Service Weight	90 kg
Suitable Standard Oil Tank	Ø580 × H890 mm

## MODEL: OT-50 STANDARD OIL TANK TRUCK

Clamp method: quickly clamp upper and lower



Lift Capacity	300 kg
Truck Width	900 mm
Truck Length	850 mm
Truck Height	1200 mm
Wheels	11"
Service Weight	26 kg
Applicable Standard Oil Tank	Ø580 × H890 mm
	Ø610 × H880 mm



## OTH-500-2 OIL TANK HOLDER(FOR TWO TANKS)

1. CAPACITY : 600 kg
2. LENGTH : 900 mm (W/O HOLDER)
3. WIDTH : 1200 mm
4. HEIGHT : 830 mm
5. FORK LENGTH : 790 mm
6. OPERATION HEIGHT : 720 mm



## OTH-300-2 OIL TANK HOLDER

1. CAPACITY : 600 kg
2. LENGTH : 900 mm (W/O HOLDER)
3. WIDTH : 1000 mm
4. HEIGHT : 830 mm
5. FORK LENGTH : 790 mm
6. OPERATION HEIGHT : 720 mm

**PPS-20LT  
LIFT TABLE STACKER**



P14

**PPS-03LRT/1450  
ROTATING LIFT TABLE TRUCK**



P14

**PPS-03 LRT/1450  
ROTATING LIFT TABLE TRUCK**



P14

**PPS-10/15/20TL  
TABLE LIFT TRUCK**



P14

**PPS-10W/15W/18W/20W  
SHAFT CARRIER STACKER**



P17

**PPS-10W/15W/18W/20W  
ROLLER CARRIER STACKER**



P17

**PPS-10W/15W/18W/20W  
STAINLESS STEEL FORK  
STACKER**



P17

**PPS-10/15/18/20+  
HOOK**



P14

**EPS-04 ECONOMIC POWERED  
STACKER (400 KG)**



P36

**SPS-10 SEMI-POWERED  
LIFTING PALLET STACKER  
+CAGE**



P36

**SPS-04  
SEMI POWERED STACKER**



P36

**DOCK LEVELER**



P34

**OTH-500-2 OIL TANK HOLDER**



P38

**ROLL CAGE TROLLEY**



**WIRE CAGE**



**HPT-20  
WEIGH SCALE HAND PALLET  
TRUCK**



P33

**MPL-50/65/80/95/110  
DPL-95/110/130**



**RACKS**



**TABLES FOR BATTERY  
CHANGE**



**PLASTIC PALLET**



**PPT-18/20/25/30/40+  
BACK REST**



P26

**PPT-18/20/25/40+  
4 FORKS PALLET TRUCK**



P26

**PPT-20LC  
ORDER PICKER TRUCK**



P26

**PPT-18/20/25/30/40+ SPECIAL  
WIDER FORKS**



P26

**PPT-18/20/25/30/40+  
STAINLESS STEEL  
PALLET TRUCK**



P26

**PPT-20/25/30/40  
SPECIAL PALLET TRUCK**



P26

**PPT-15  
SPECIAL NARROW FORK  
TRUCK**



P26

**PPT-18/20/25/30/40  
ROLLER CARRIER TRUCK**



P26

**APT-20  
HYDROGEN FUEL CELL  
PALLET TRUCK**



P18

**ART-15+ CRANE ARM**



**PPT-80/100/150  
PALLET TRUCK**



P26

**PPT-80/100/150  
PALLET TRUCK**



P26

**PPT-20  
SPECIAL TOW TRUCK**



P26

**TT-50+SIDE GUARD  
TOW TRUCK**



P31

**TT-50+SIDE GUARD  
TOW TRUCK**



P31

**ET-10  
ELECTRIC TRUCK**



**CRT-10/15  
SPECIAL REACH TRUCK WITH  
BOOM**



**CRT SPECIAL REACH TRUCK**



**AGF (AUTOMATIC FORK LIFT  
TRUCK)**



**PMGV (FULL STAINLESS  
STACKER)**

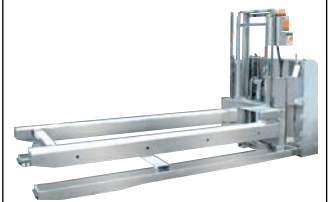

**ABF-15/20/25 +  
BALE CLAMP (AC)**



P4

**ABF-15/20/25 +  
ROTATING FORK CLAMP (AC)**



P4

**ART-10/15/20 +EPS (AC)  
REACH TRUCK +  
OVERHEAD GUARD**



P5

**ACS-05/08/10/12/15 +EPS (AC)  
COUNTERBALANCED  
STACKER+BOOM**



P8

**APT-20/25/30  
PALLET TRUCK + CASE**



P18

**APT-20/25/30(AC)  
PALLET TRUCK COVERED BY  
STAINLESS STEEL**



P18

**CRT-10/15(DC) REACH TRUCK  
+FOLDABLE FORK**



**Digital weight Scale Forks**



**PPS-10/15/20  
STACKER +CASE**



P14

**PPS-10/15/20 STACKER +  
OVERHEAD GUARD**



P14

**PPS-10/12 SIDE MAST+ REACH  
MAST STACKER**



P14

**APS/PPS+ Scoop**



P17



**NOVELTEK INDUSTRIAL MANUFACTURING INC.**

TEL: 886-37-220-741

FAX: 886-37-226-152, 886-37-220-849

SKYPE: NOVELTEK

ADDRESS: No. 16-1, Shui-Liu-Niang, Shui-yuan Village, 360 Miaoli City, Miaoli County, Taiwan R.O.C.

URL: <http://www.liftruck.com.tw>

URL: <http://www.liftruck.net>

E-mail: [liftruck@ms18.hinet.net](mailto:liftruck@ms18.hinet.net)

©copyright 2019.2